



Ministero per le disabilità

Regione Emilia-Romagna

VISIT EMILIA ROMAGNA



# WelcomeEverybody

Emilia Romagna

# Strumenti e servizi a supporto del turismo inclusivo

di *Leris Fantini*



Prodotto creato nell'ambito del progetto In Emilia-Romagna c'è una vacanza per me, realizzato con il contributo della Presidenza del Consiglio dei ministri - Ministro per le disabilità

## Chi siamo?

Attualmente, i soci distribuiti a livello nazionale, sono professionisti che si occupano di soluzioni per **l'accessibilità**, di **benessere ambientale**, di **mobilità** e di **comunicazione**, di **informazione** e **formazione**, di **turismo**, di **design** e di **aspetti legali e sociali**.



# Le principali azioni nel settore del turismo accessibile in Italia

- Progetto Europeo: A.V.A.N.T.I. (1992/1995)
- Progetto nazionale STARe: Italia per tutti (1999/2001)
- Costituzione dell'Associazione Si Può 2001
- Organizzazione Fiera Easy sul turismo accessibile (2001)
- Progetto Europeo Equal: Albergo in via dei matti n. 0 (2001/2005)
- Progetto interreg: C.A.R.E. (2005/2006)
- Progetto Interreg: I.I.T.T. (2011/2012)
- Definizione della Carta di Norcia
- Definizione della Carta di Pollein
- Definizione del Libro bianco sul Turismo accessibile (2013)
- Il manifesto sulle spiagge accessibili



Oggi parliamo di voi operatori  
del settore turistico



# Regione Emilia-Romagna

**Obiettivo: alzare il livello di QUALITA' DELL'OFFERTA  
TURISTICA**

- Formare, sensibilizzare, informare gli operatori
- Creare strumenti professionali che facilitano il protagonismo dei consumatori/clienti



Oggi parliamo di voi operatori del settore turistico

## Occorre alzare il livello di **QUALITA' DELL'OFFERTA TURISTICA**

- Mettere in campo nuove attenzioni in grado di conquistare nuove fette di mercato ma soprattutto una fidelizzazione dell'offerta sul territorio



Oggi parliamo di voi operatori del settore turistico

## Occorre alzare il livello di **QUALITA' DELL'OFFERTA TURISTICA**

Vogliamo coniugare le ragioni dell'impresa turistica con la capacità di saper rispondere ad una domanda di “ospitalità” che richiede **attenzioni, dialogo, conoscenze tecniche.**

**BASTA POCO, A VOLTE SOLO PICCOLE ATTENZIONI**





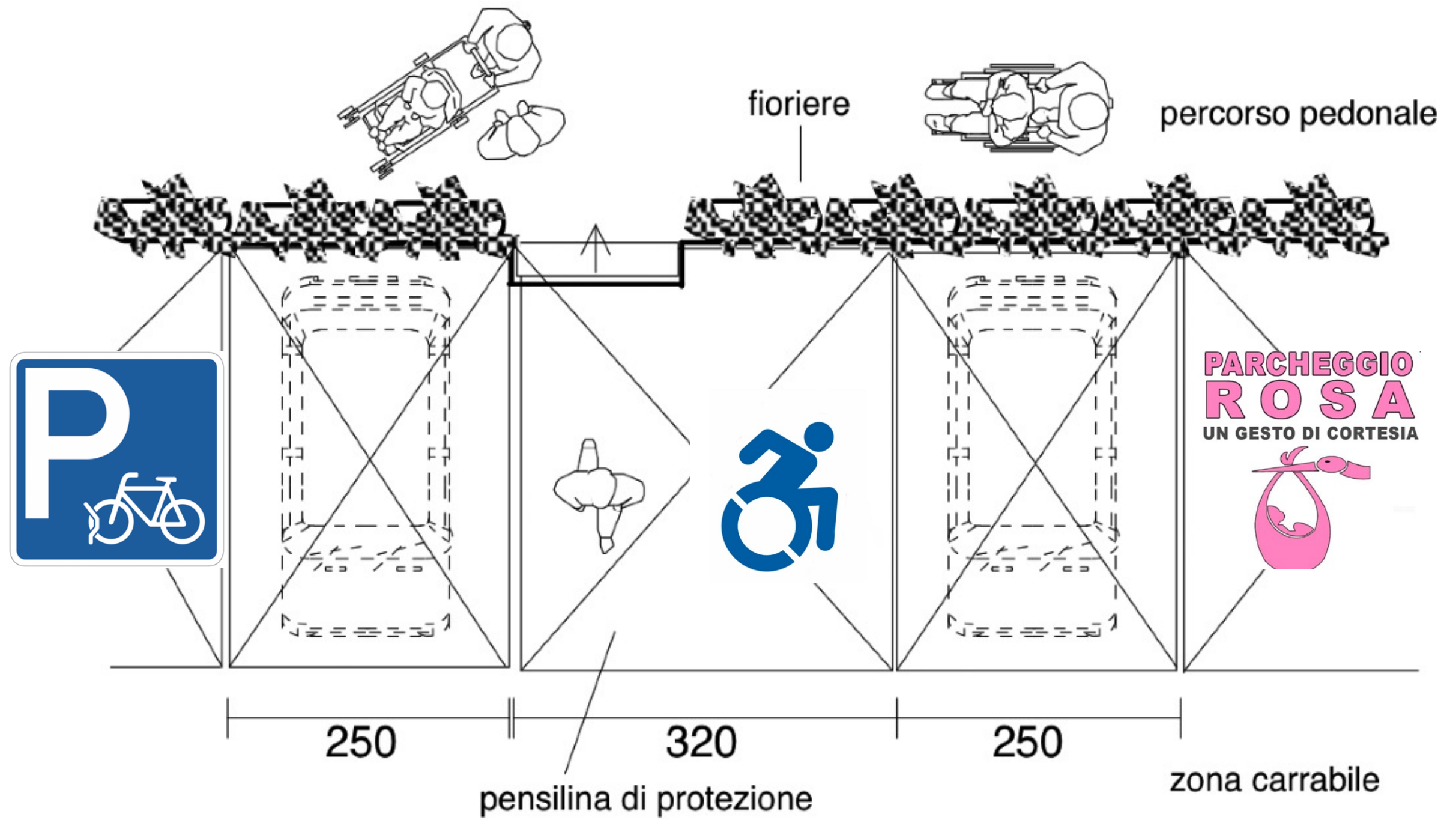





WelcomeEverybody  
Emilia Romagna

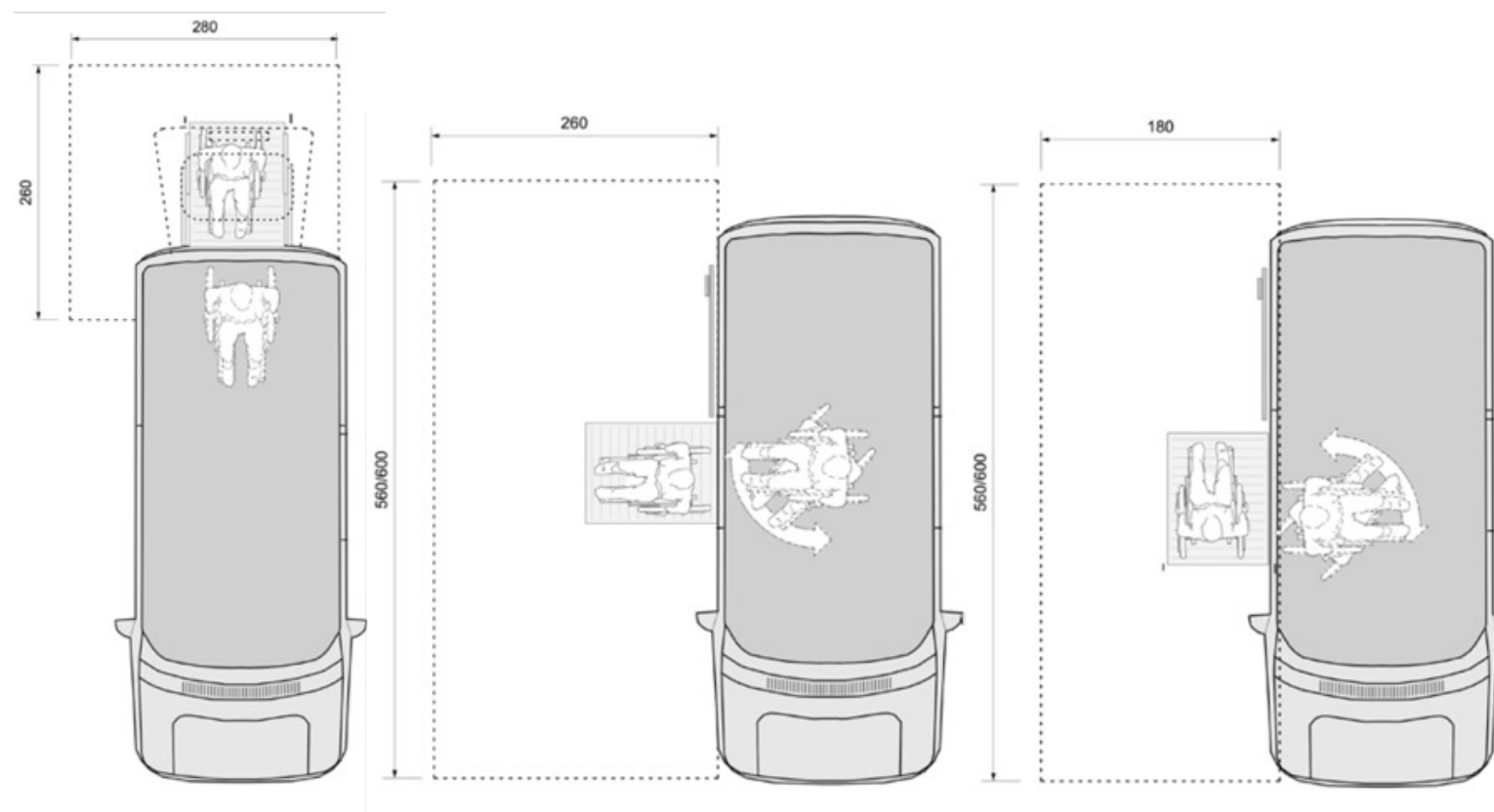
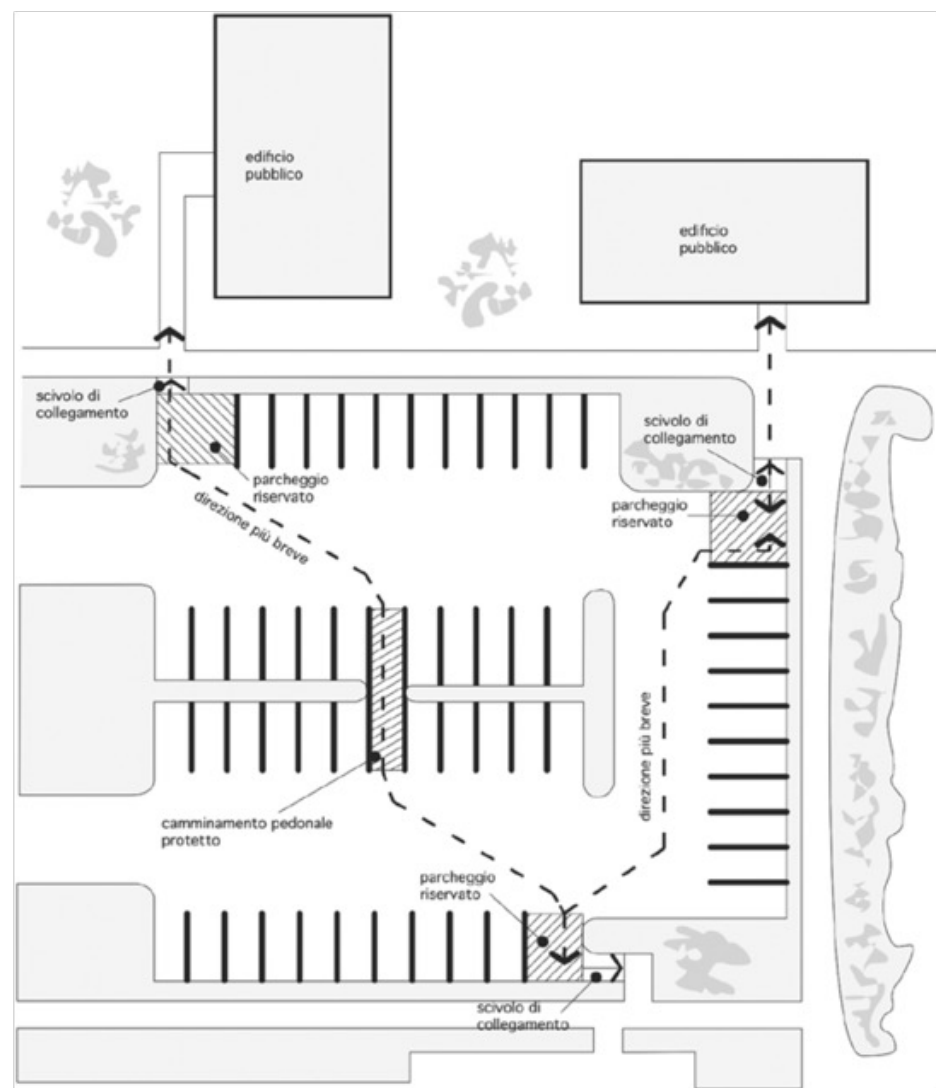

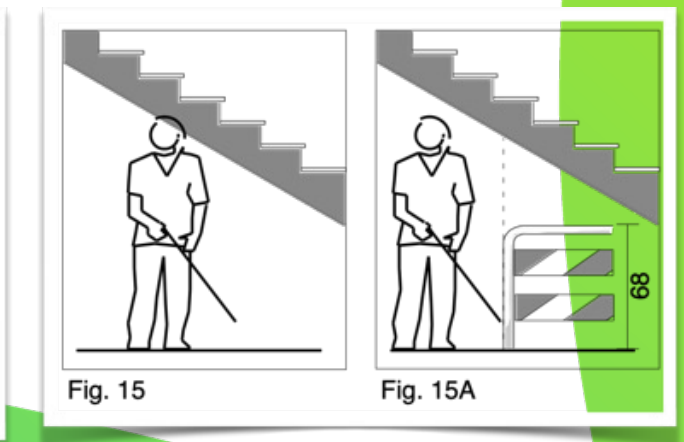
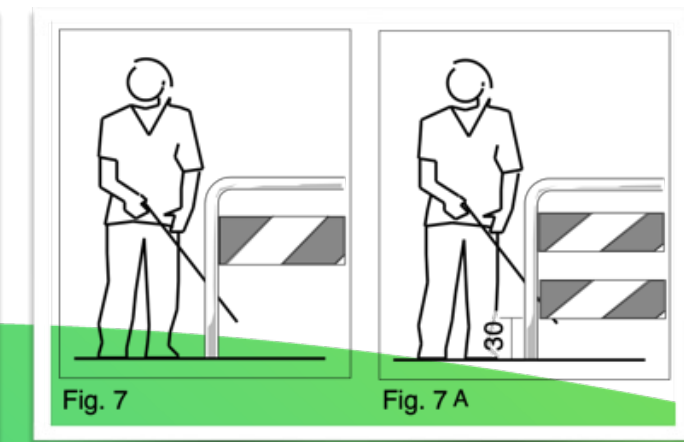
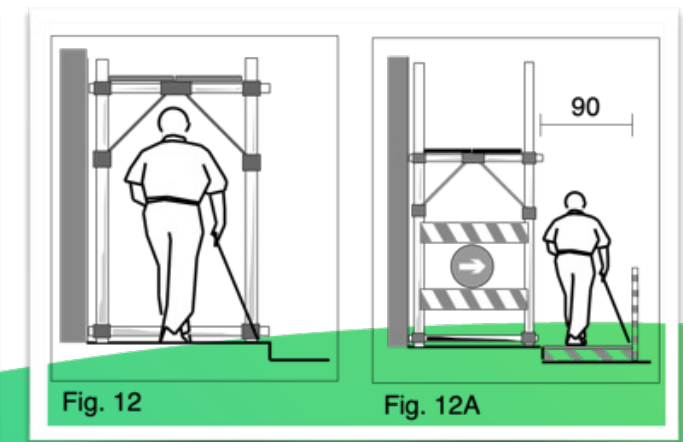
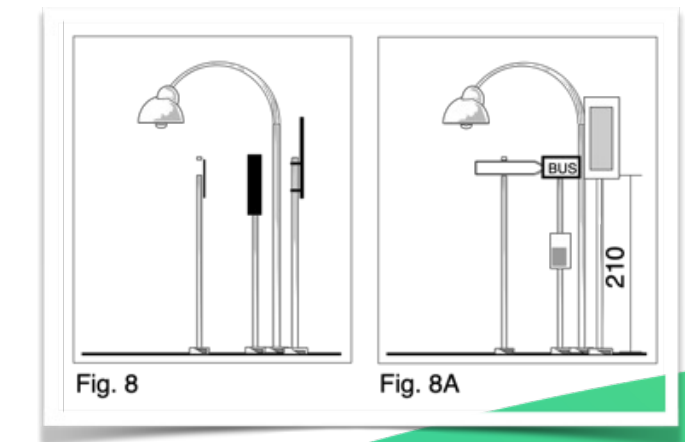
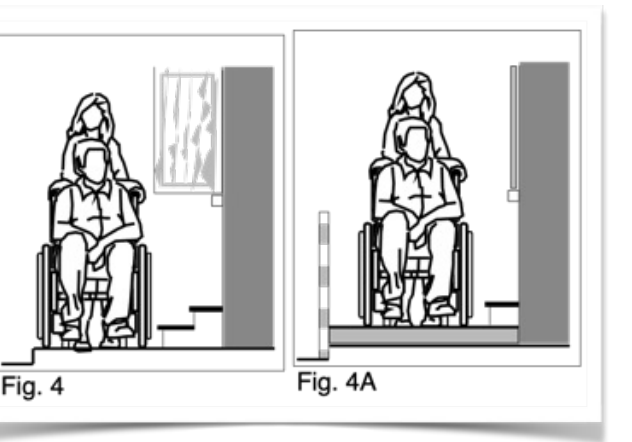
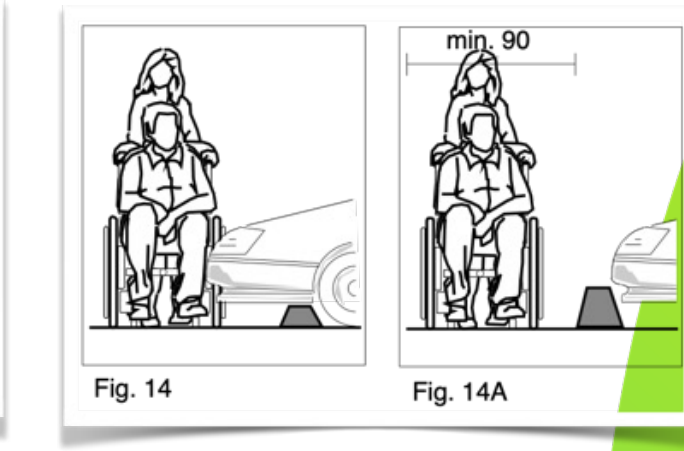
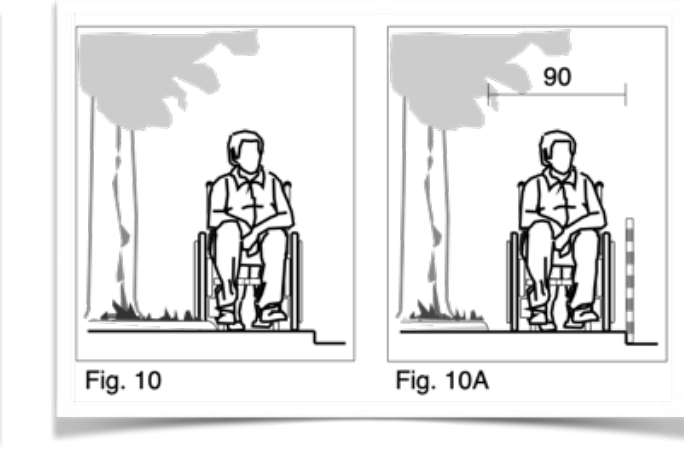
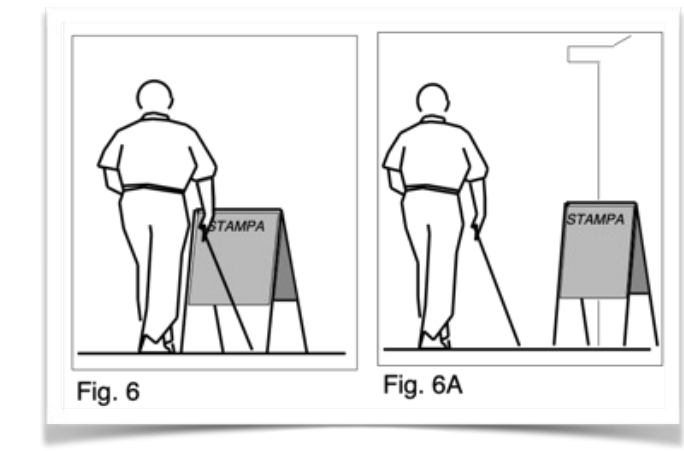
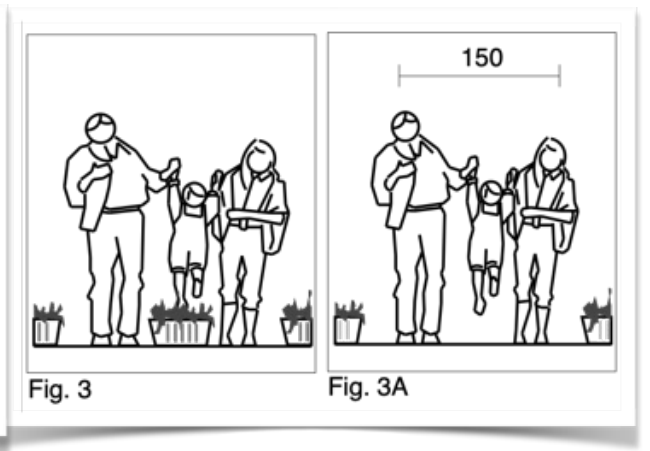
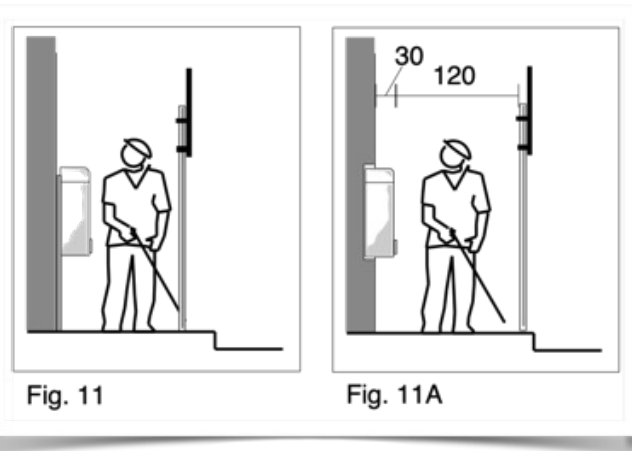
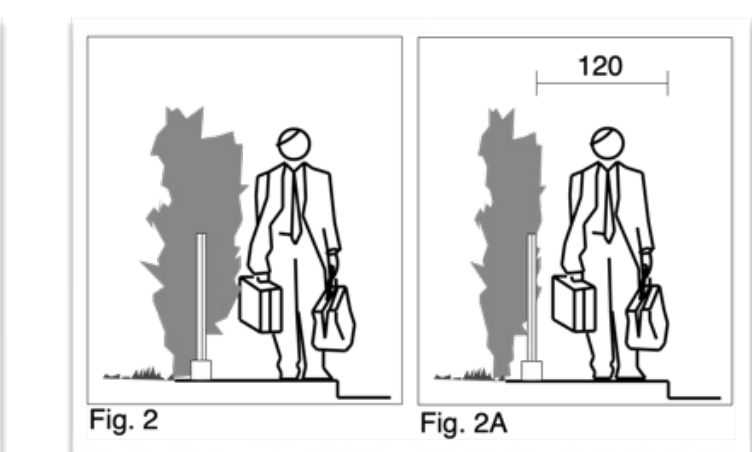
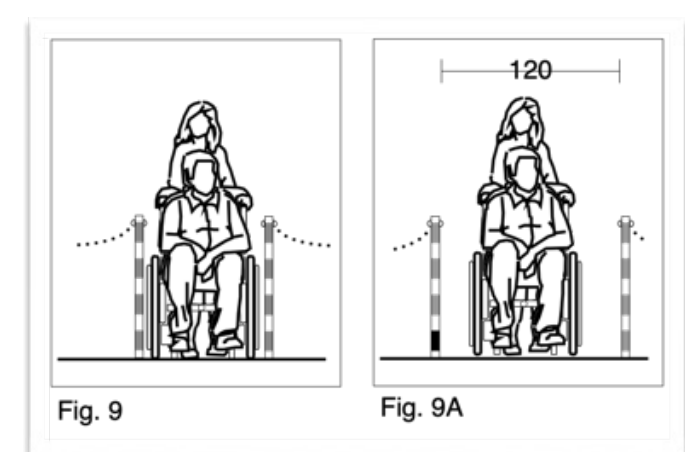
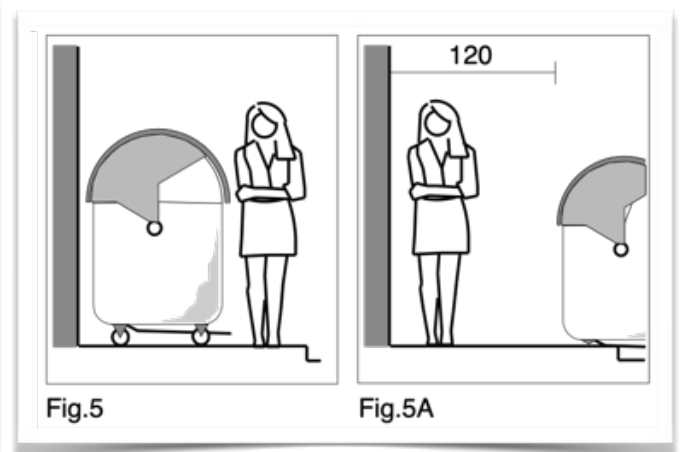
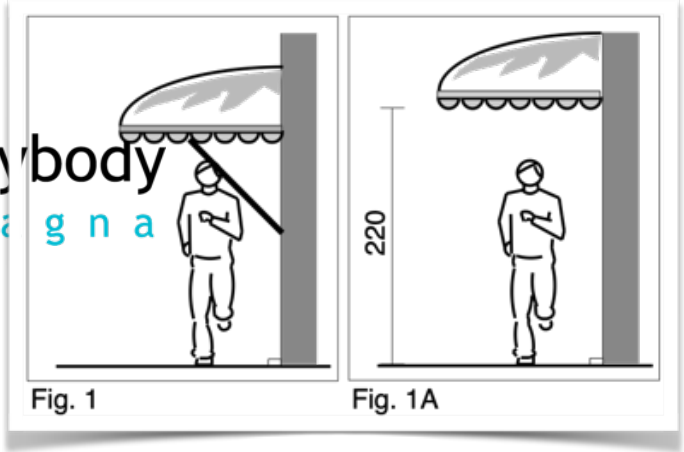









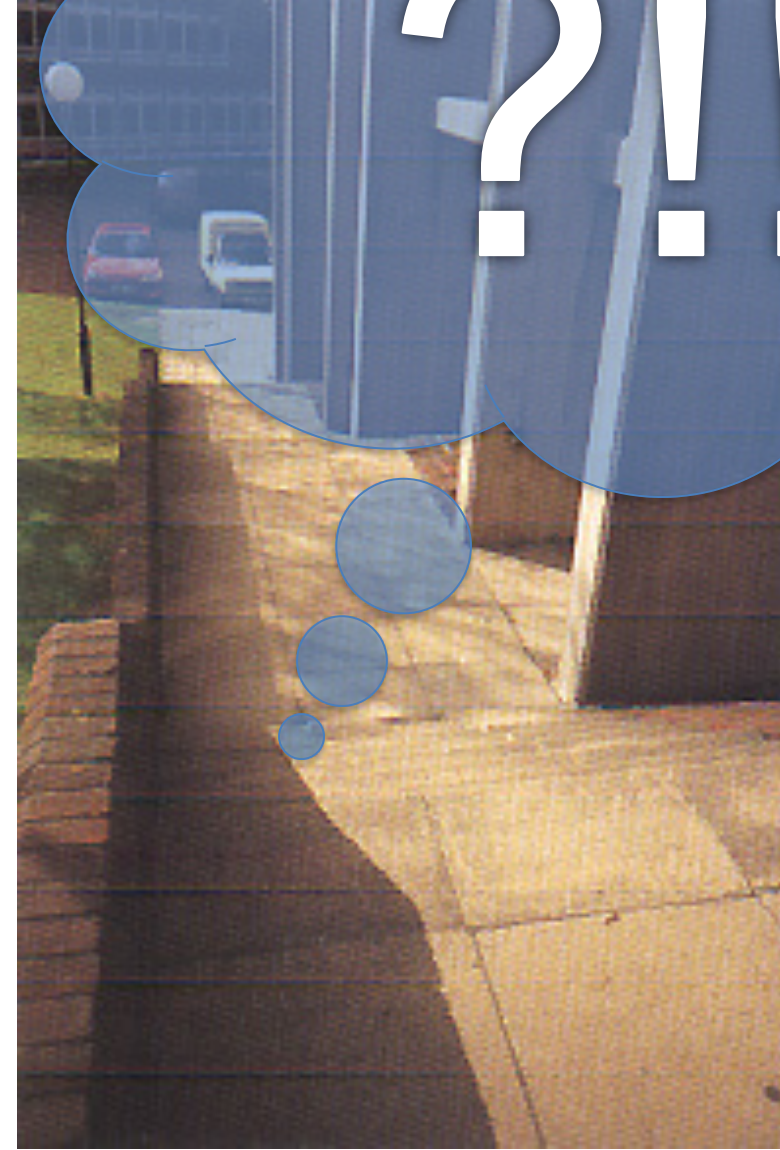





**WelcomeEverybody**  
Emilia Romagna

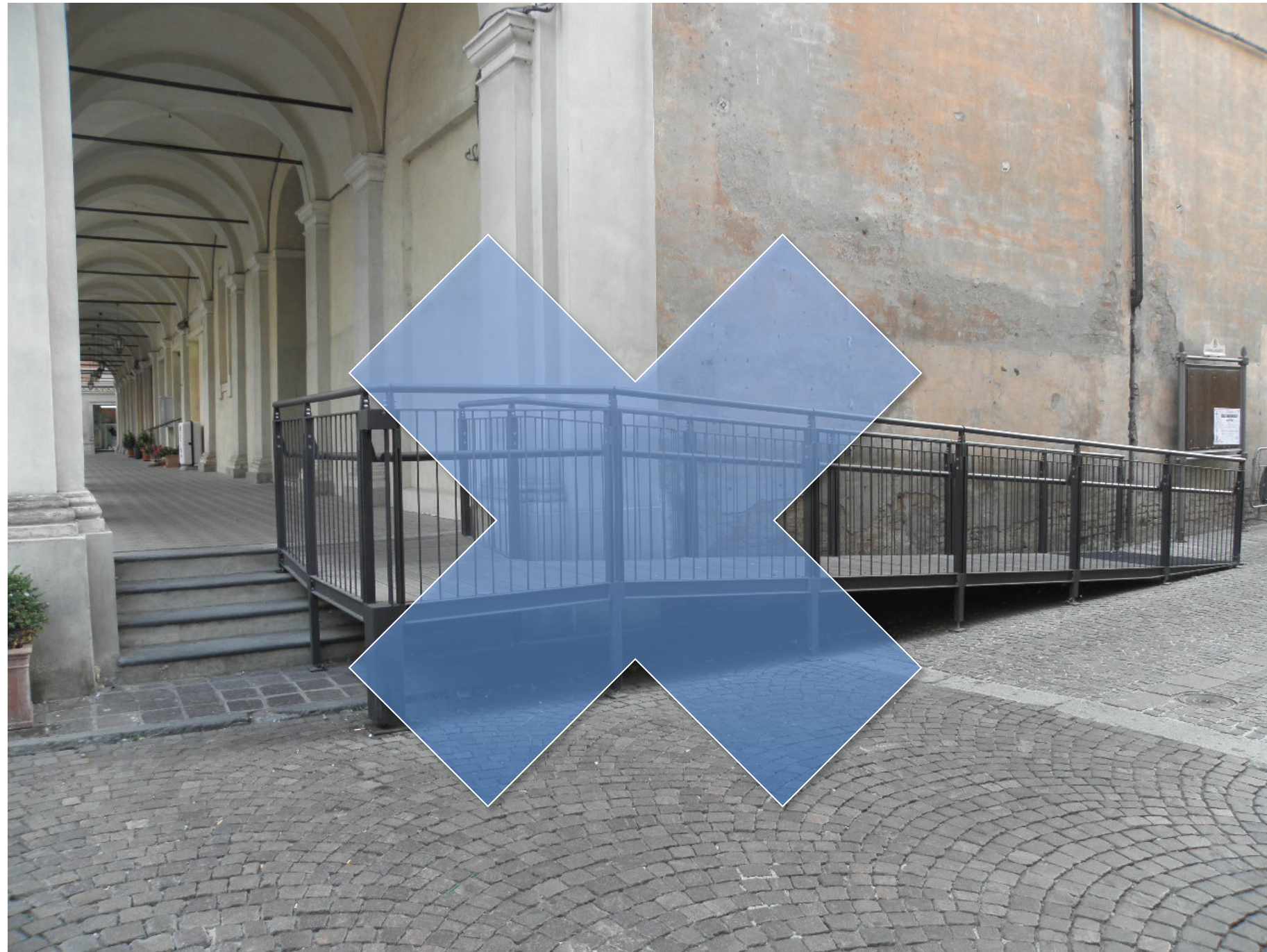



WelcomeEverybody  
Emilia Romagna



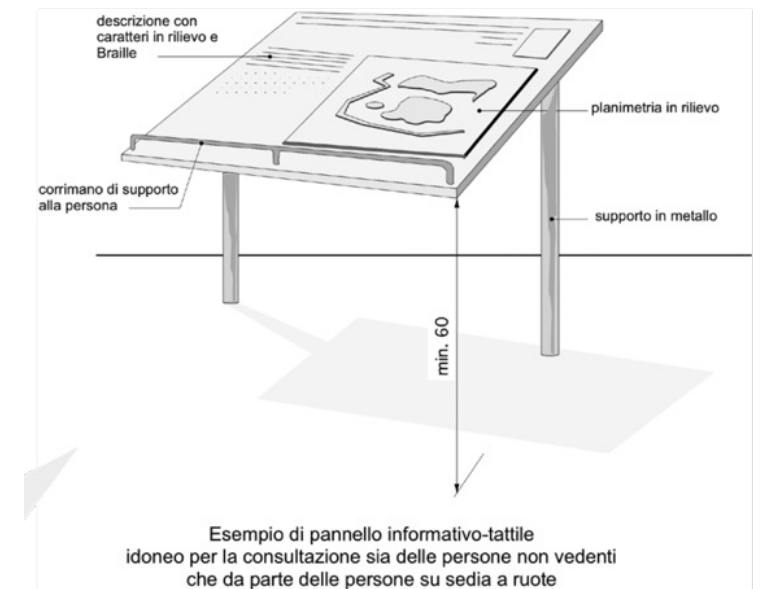
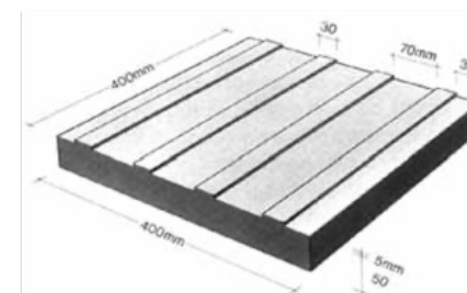
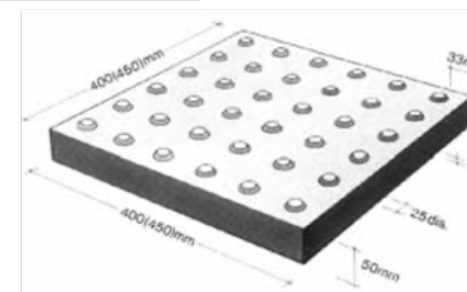
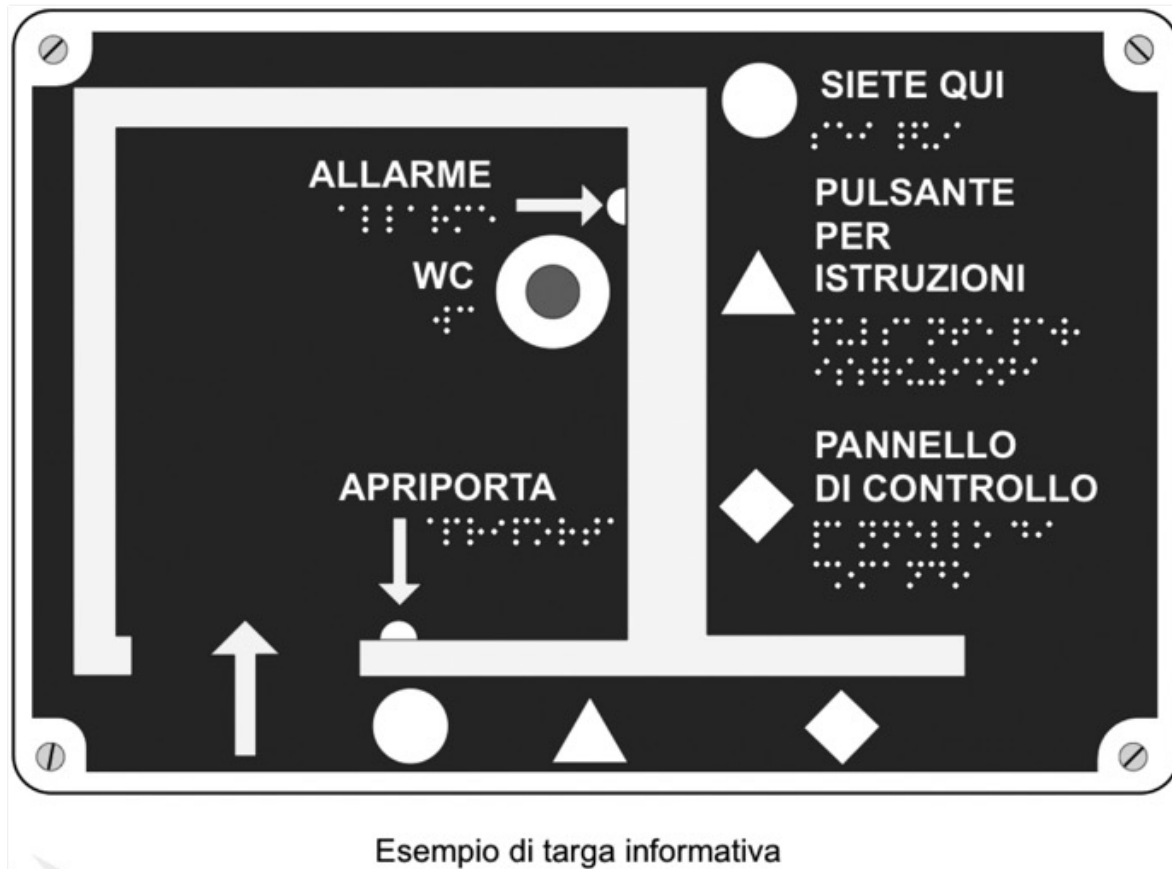
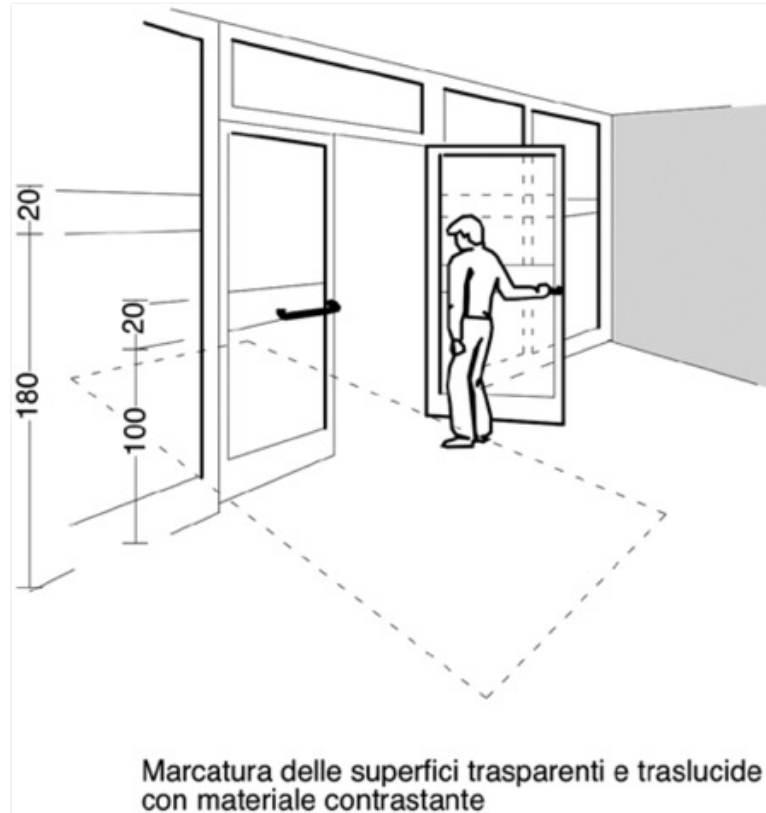



**WelcomeEverybody**  
Emilia Romagna



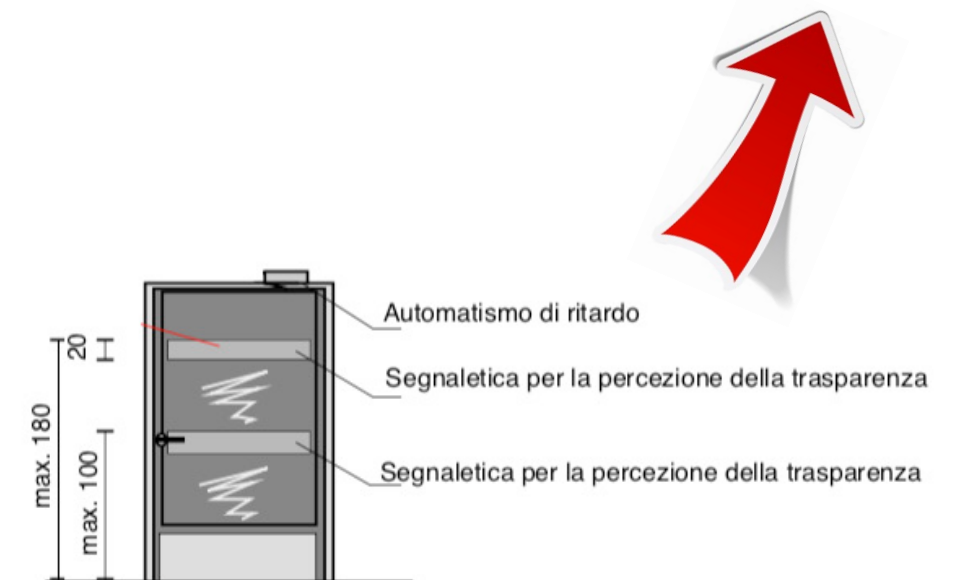







**WelcomeEverybody**  
Emilia Romagna



# video

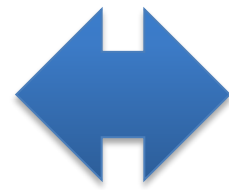

# video

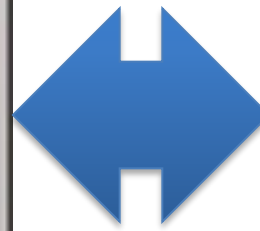

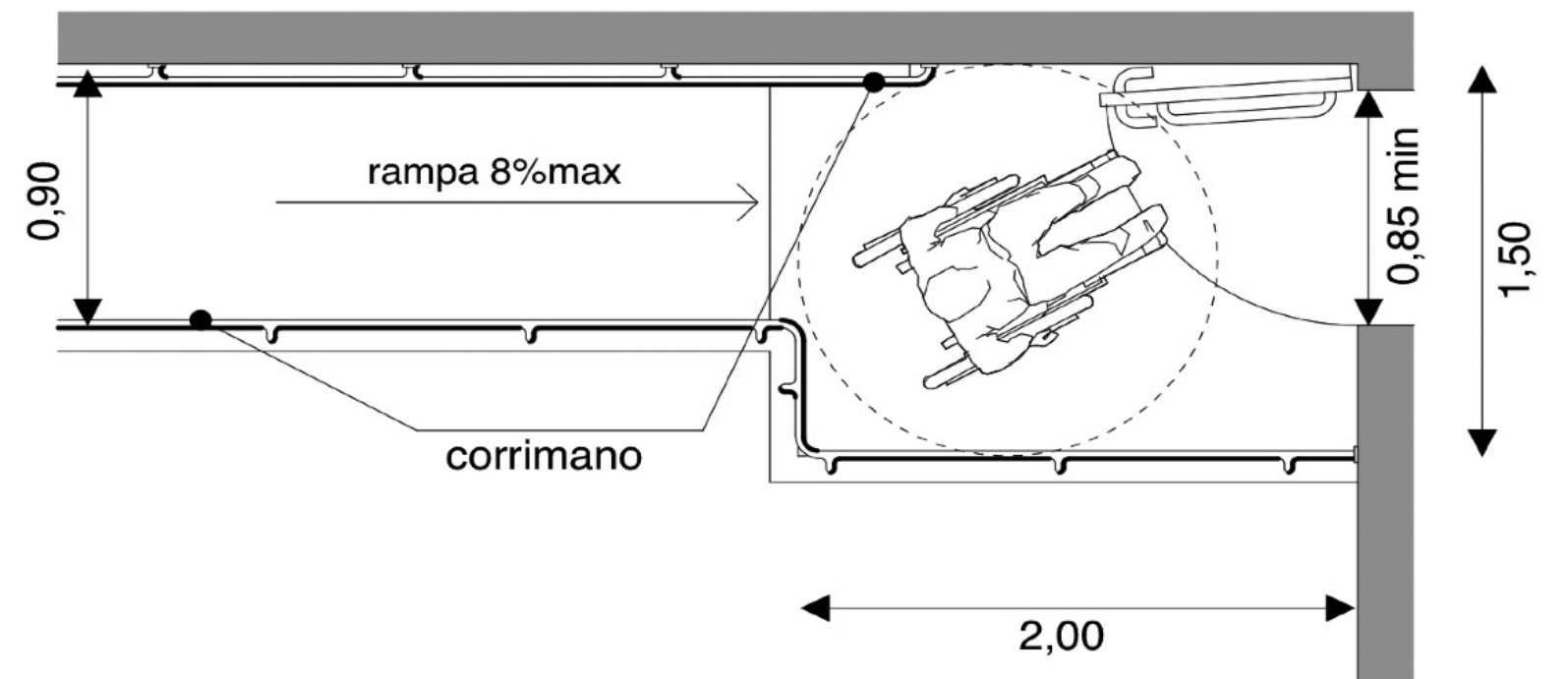
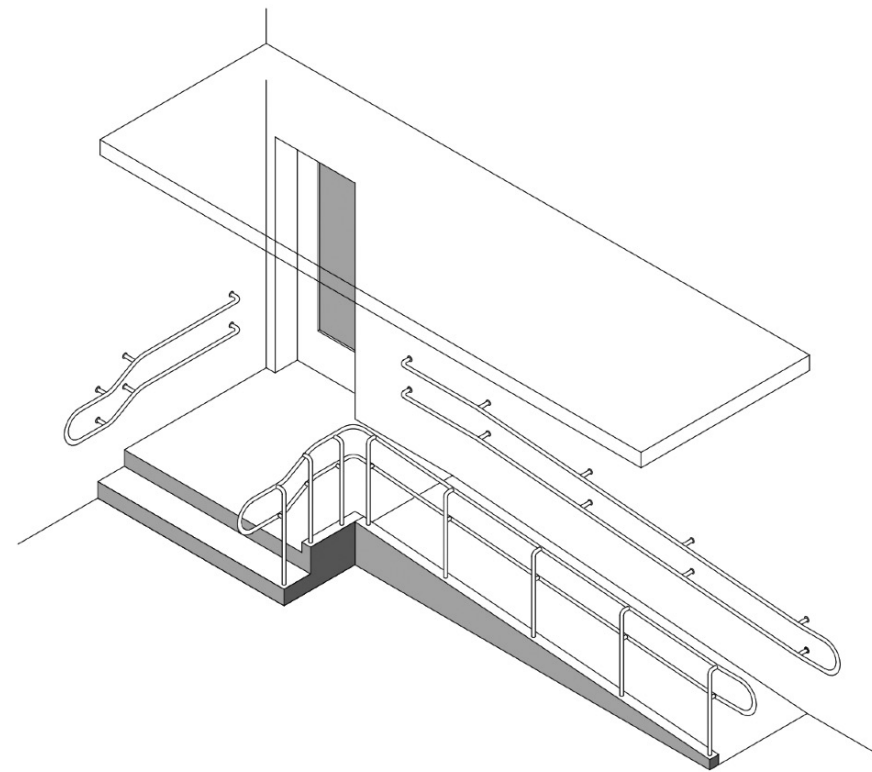
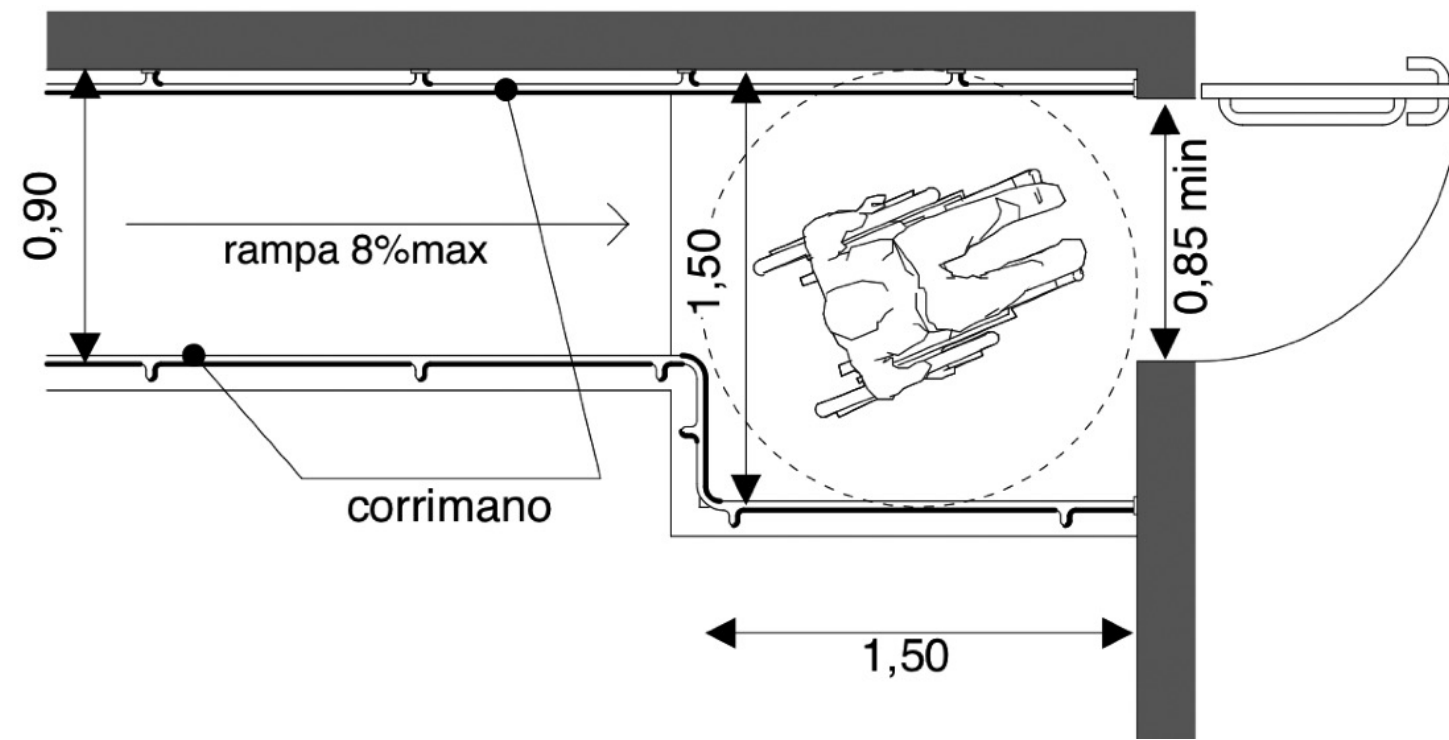

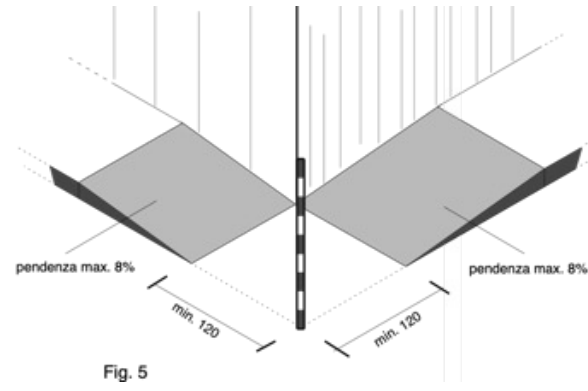

Fig. 5

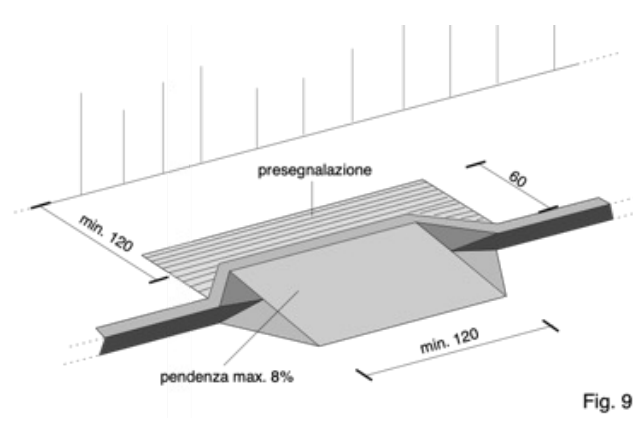

Fig. 9

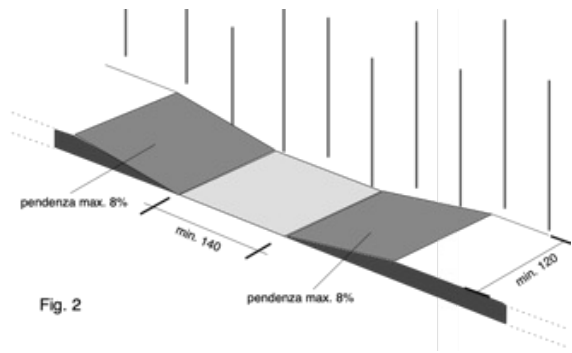

Fig. 2

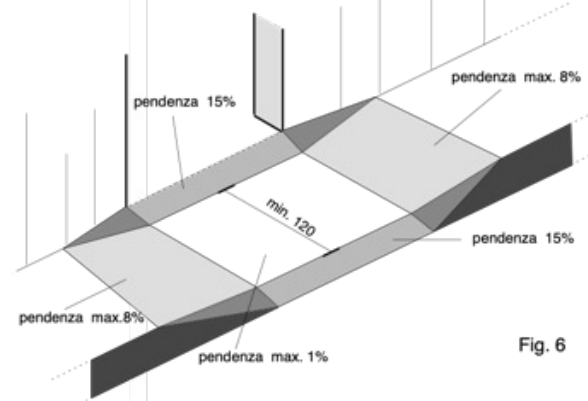

Fig. 6

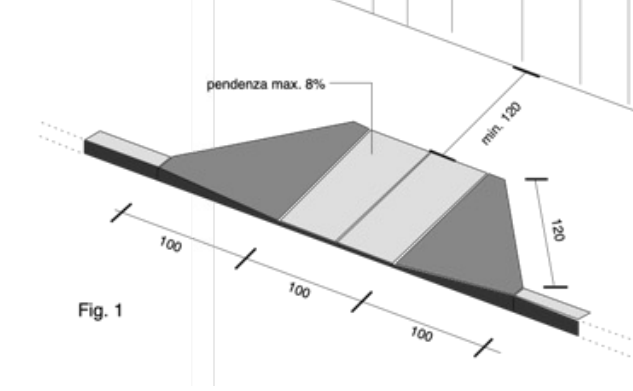

Fig. 1

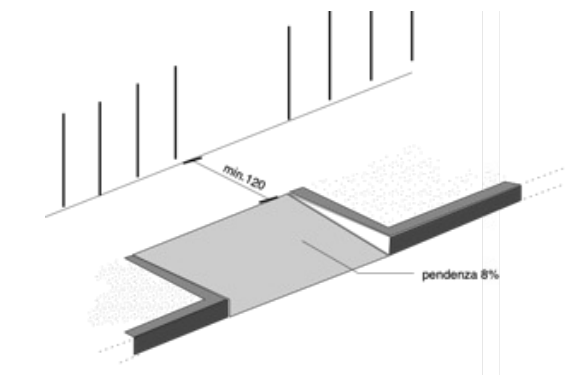

Fig. 3

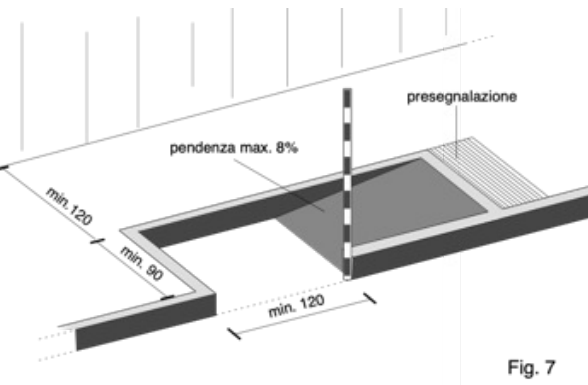

Fig. 7

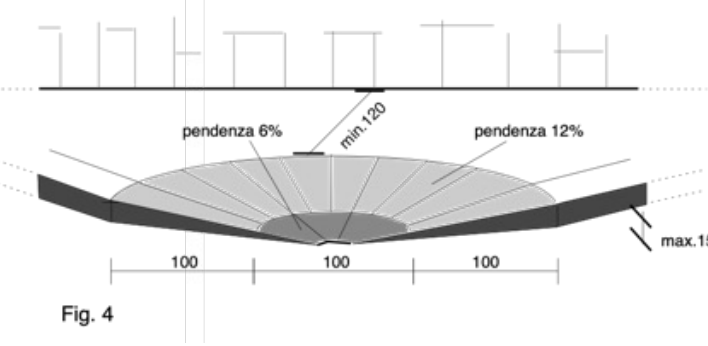

Fig. 4

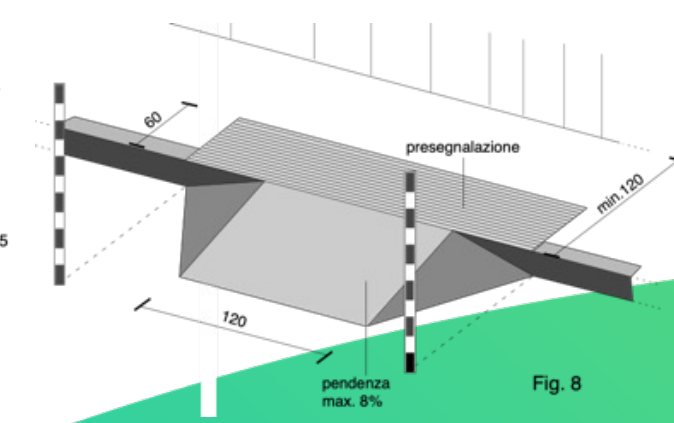
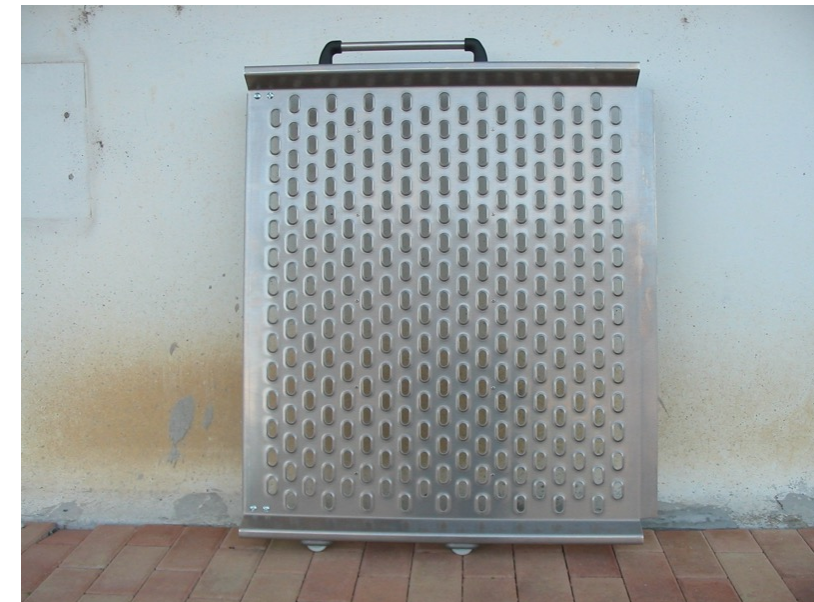

Fig. 8







# Superare la differenza di quota attraverso una tecnologia

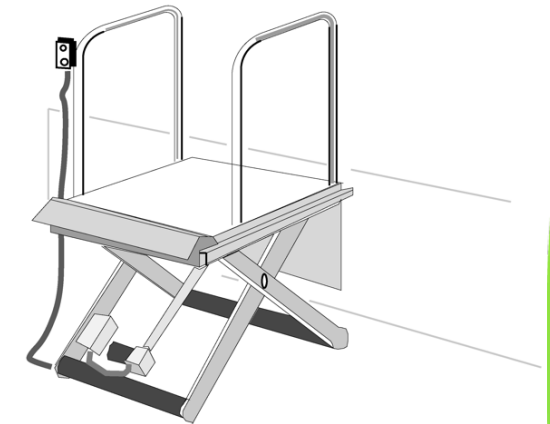

Elevatore a pantografo per il superamento di dislivelli minimi





**WelcomeEverybody**  
Emilia Romagna



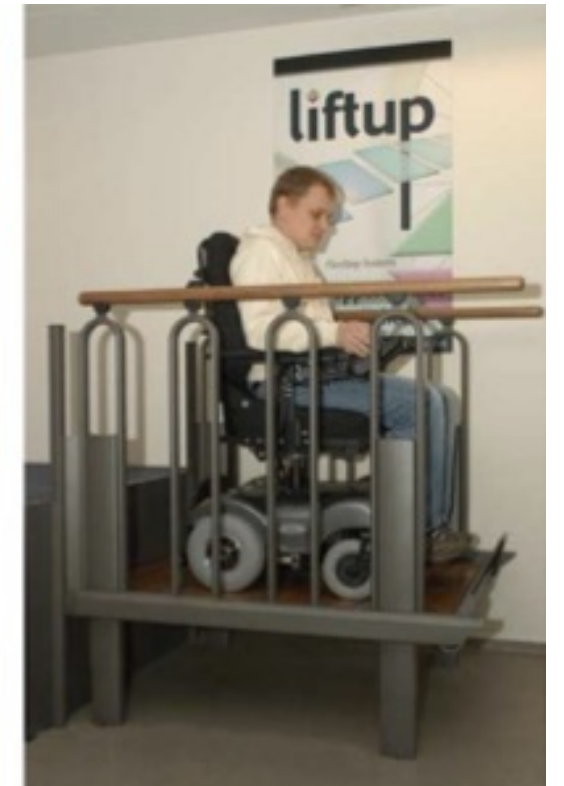
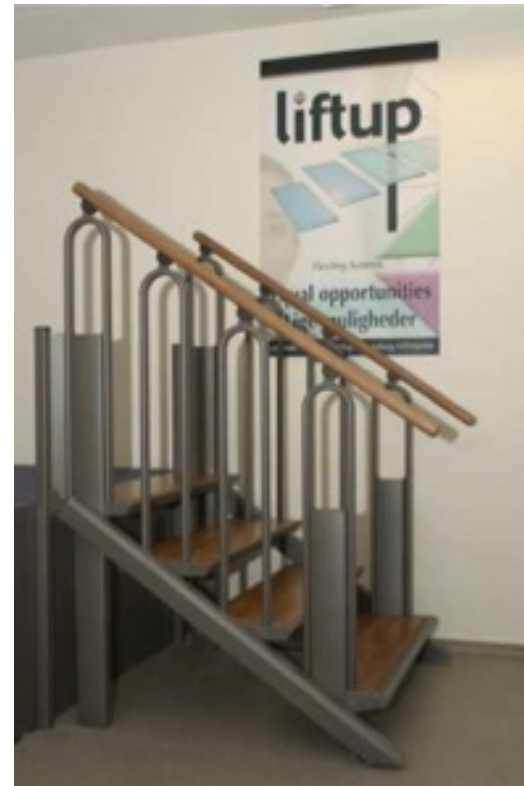
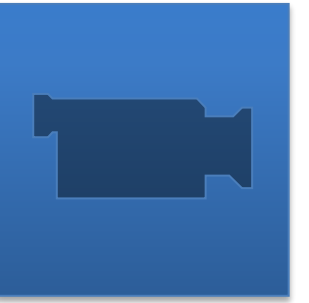



**WelcomeEverybody**  
Emilia Romagna







# Bellezza o funzionalità



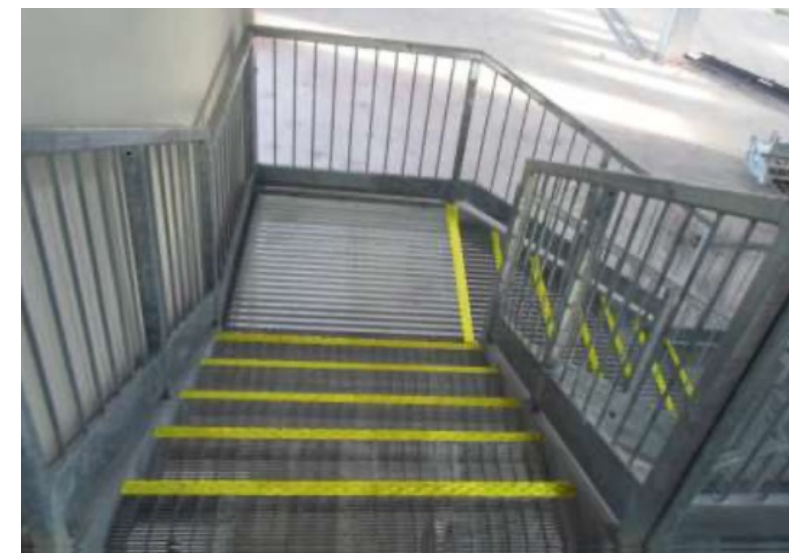
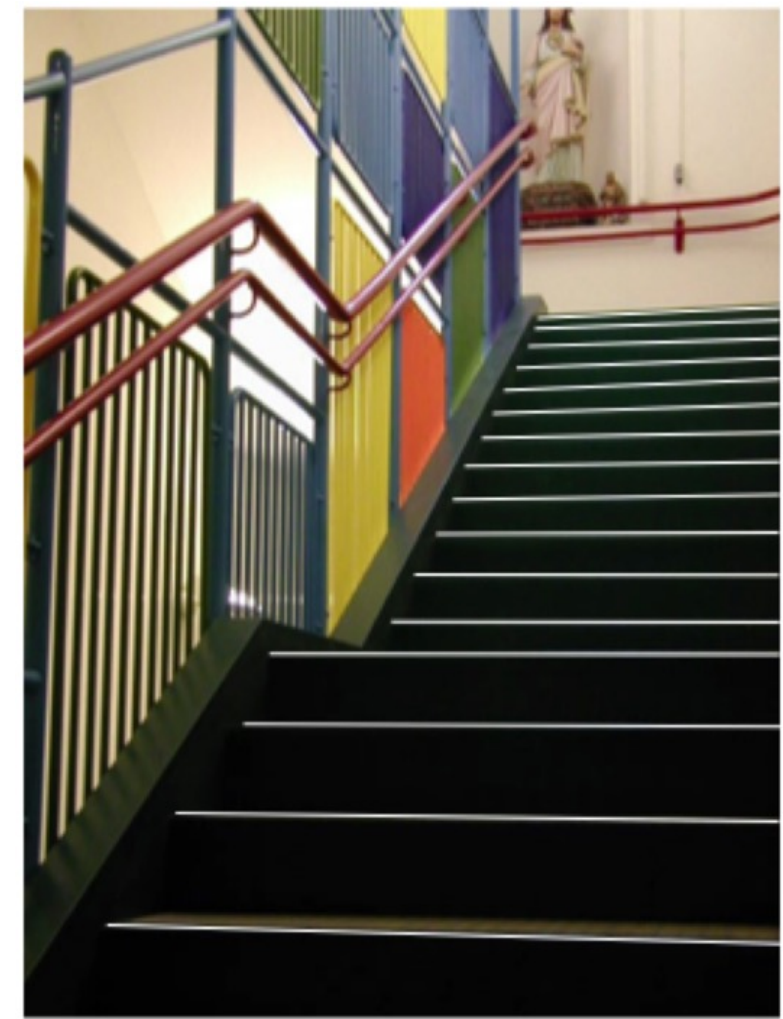

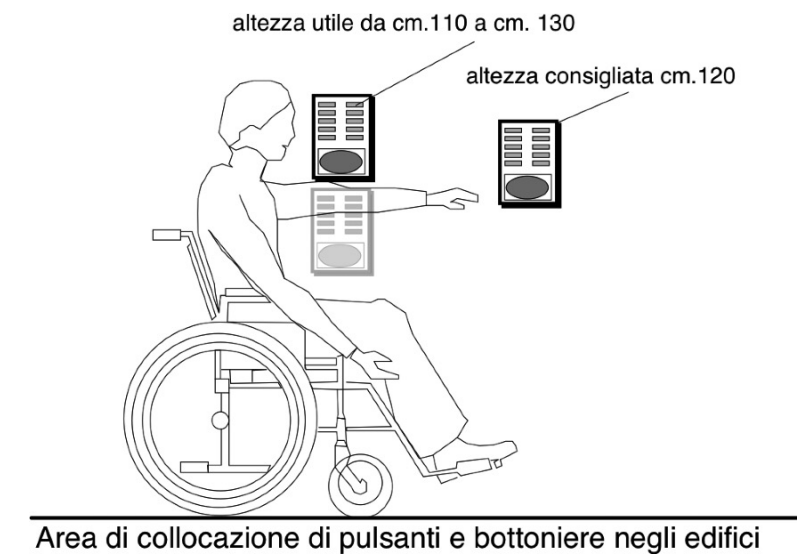
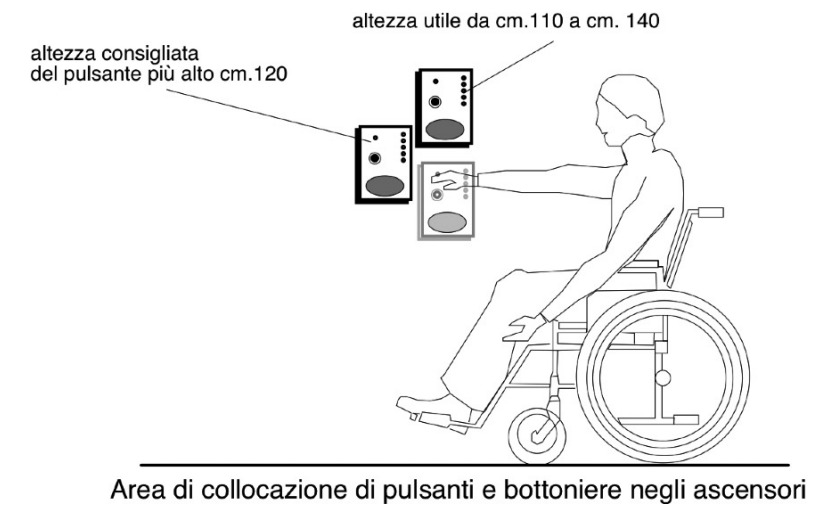
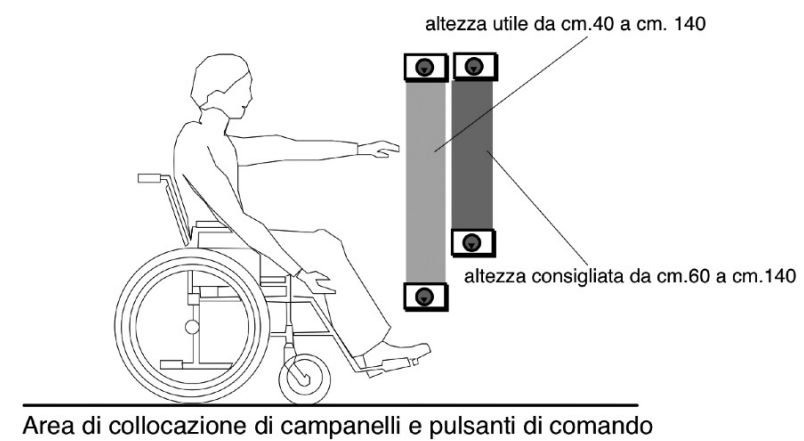
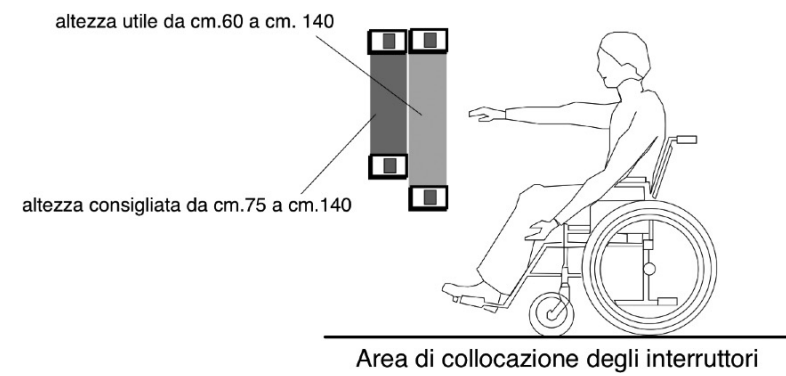
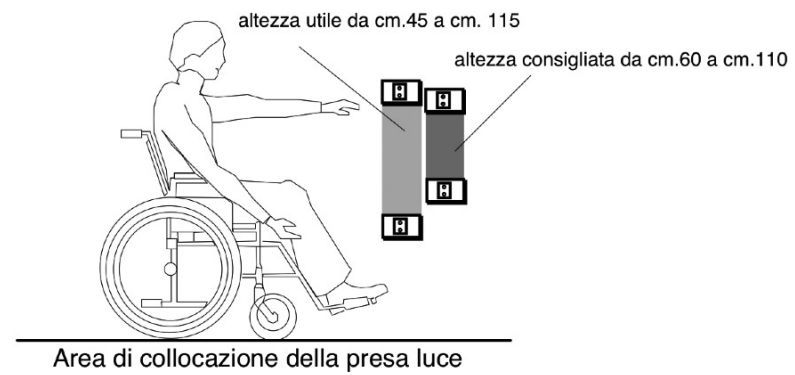





**WelcomeEverybody**  
Emilia Romagna

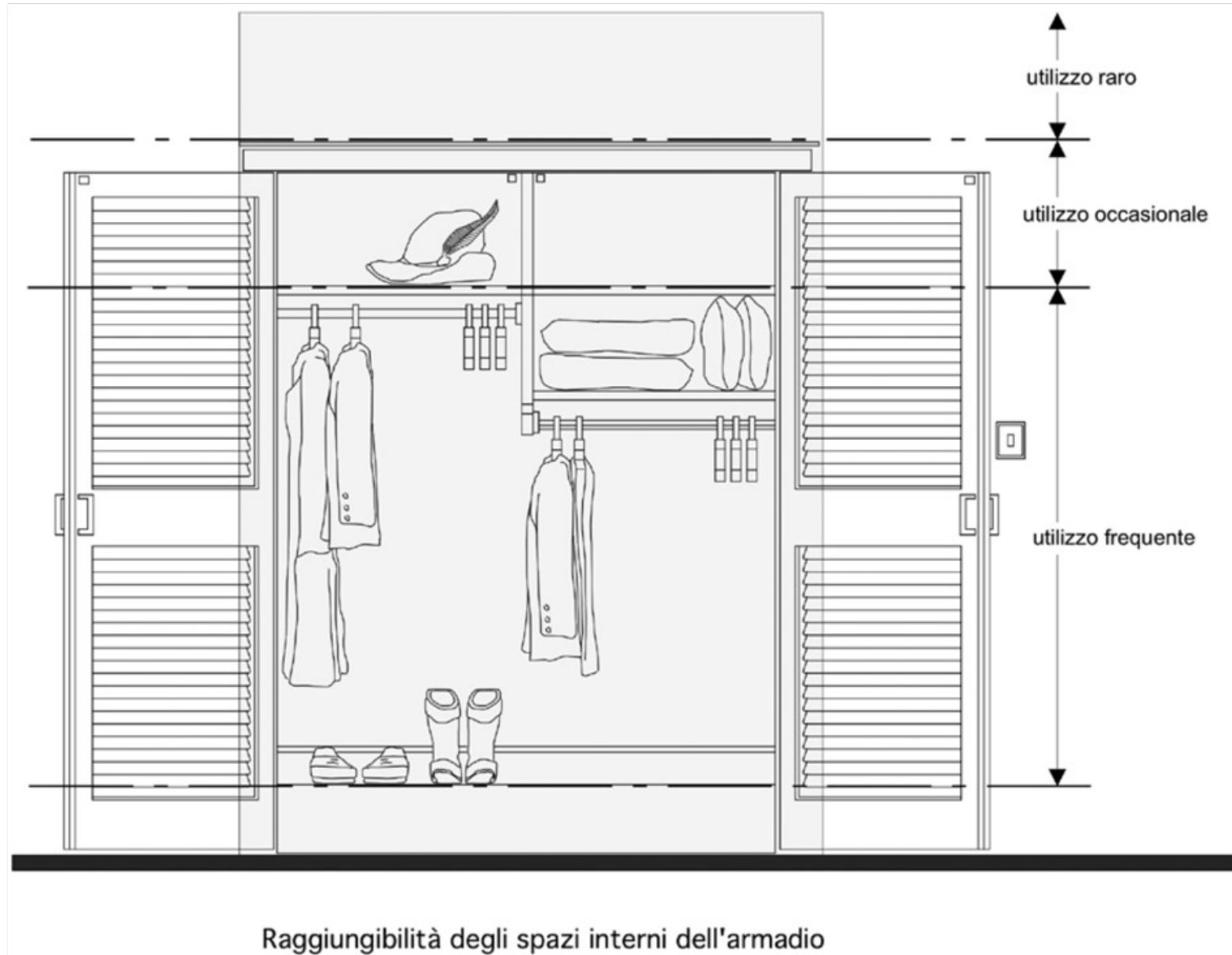

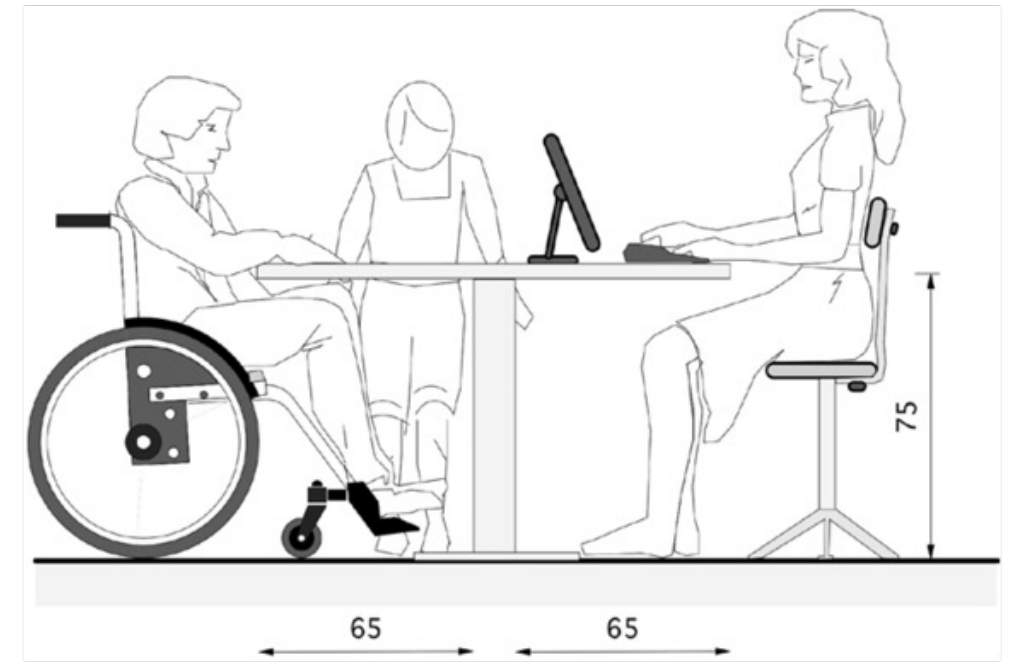
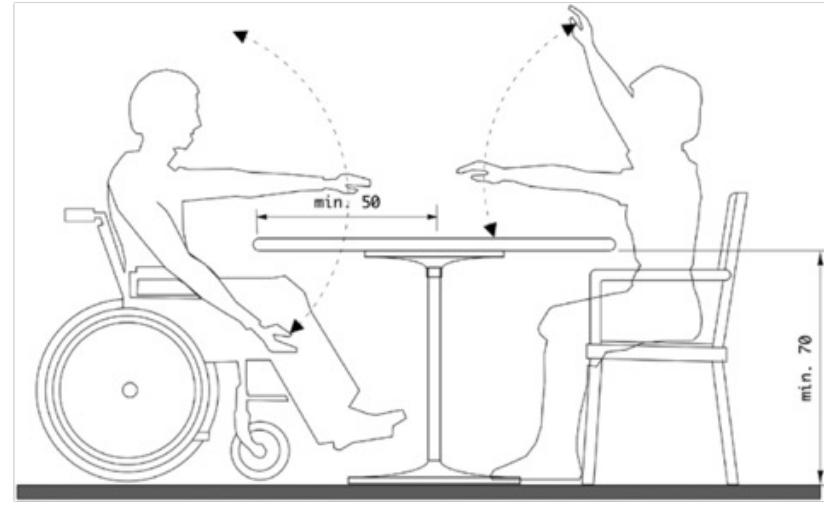
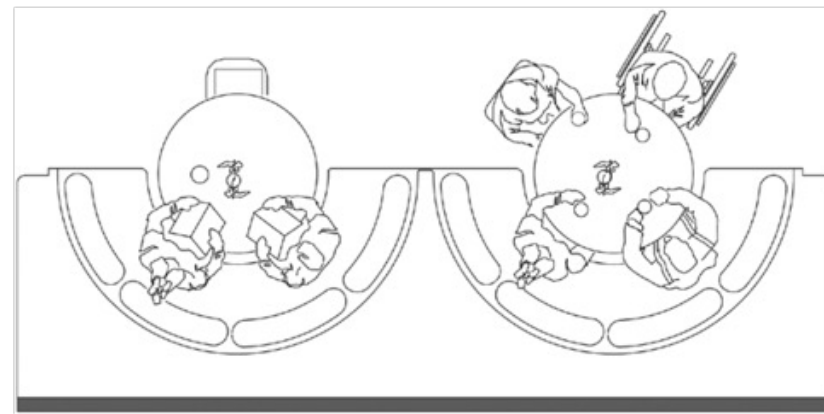
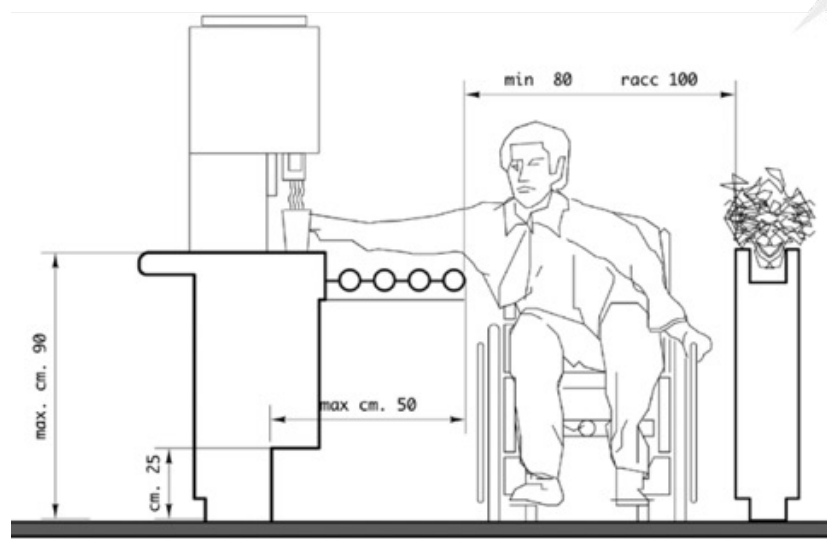

Particolare di un front-office particolarmente fruibile da persone su sedia a ruote

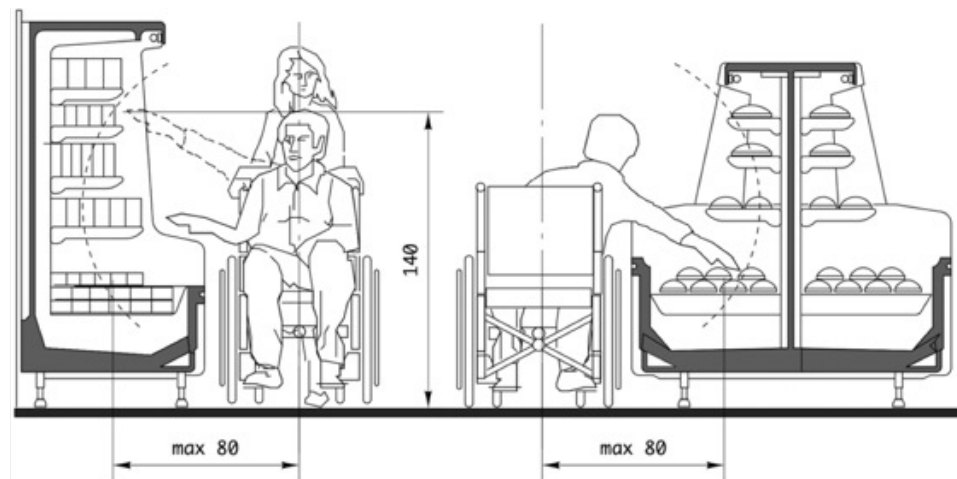

Accesso agli scaffali e ai banchi frigo

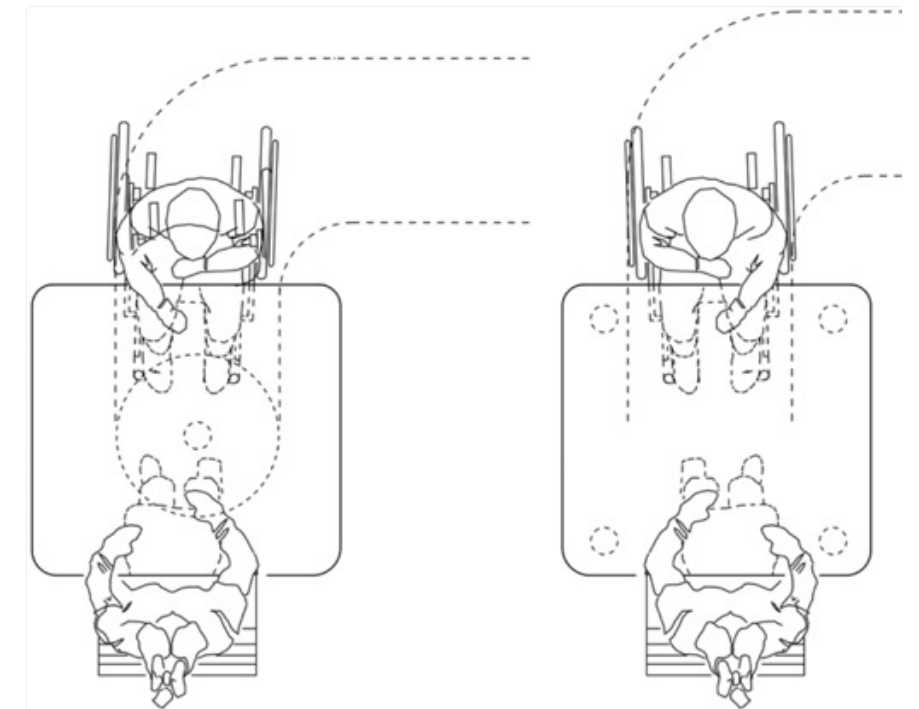
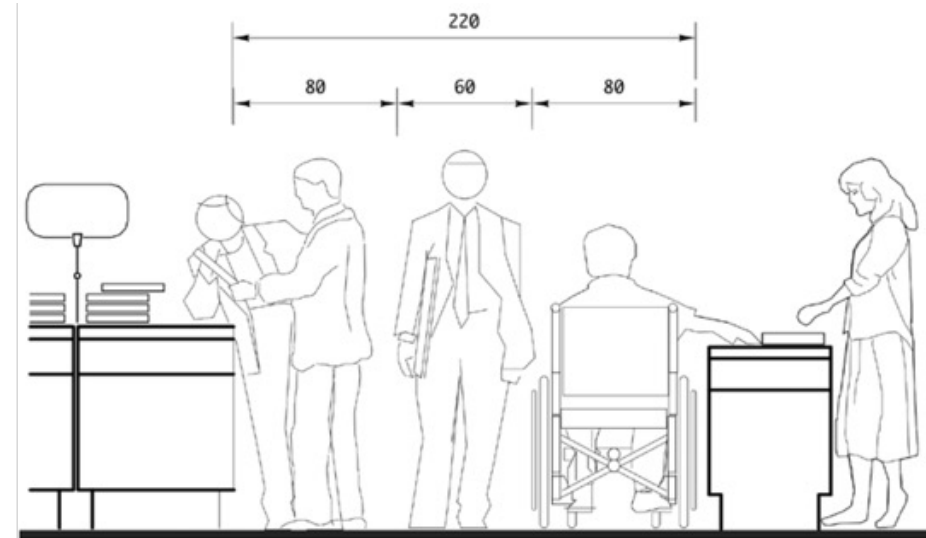

Particolare della superficie necessaria per l'accostamento al tavolo di una persona



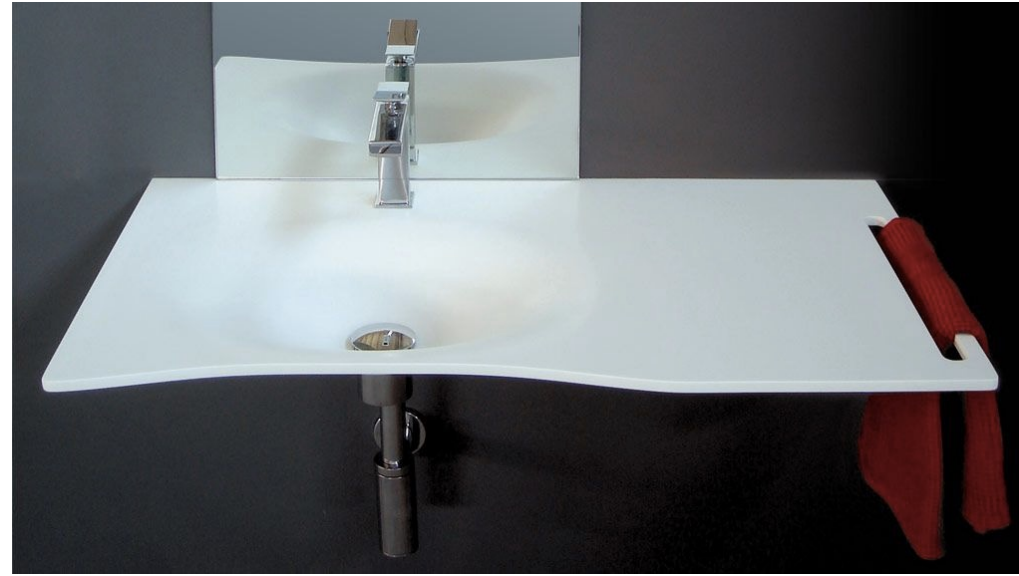





WelcomeEverybody  
Emilia Romagna

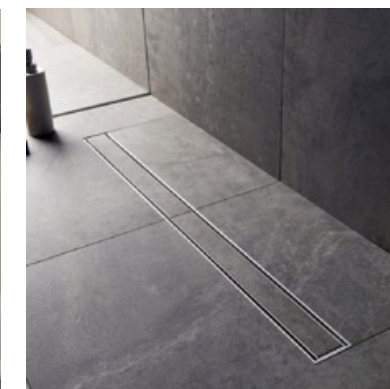



**WelcomeEverybody**  
Emilia Romagna

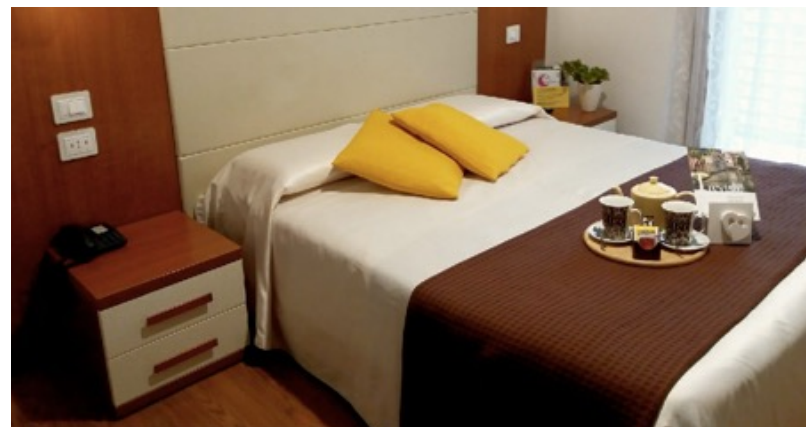



**WelcomeEverybody**  
Emilia Romagna

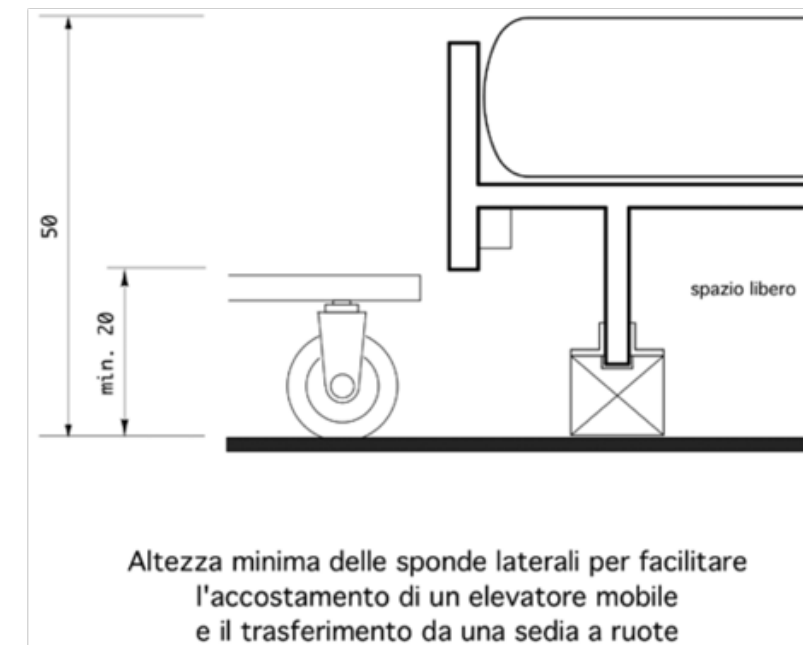
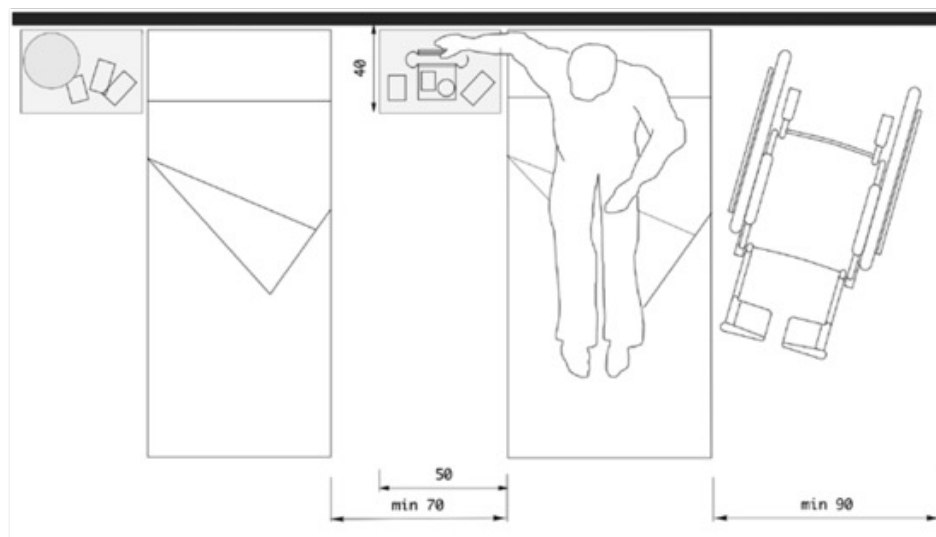
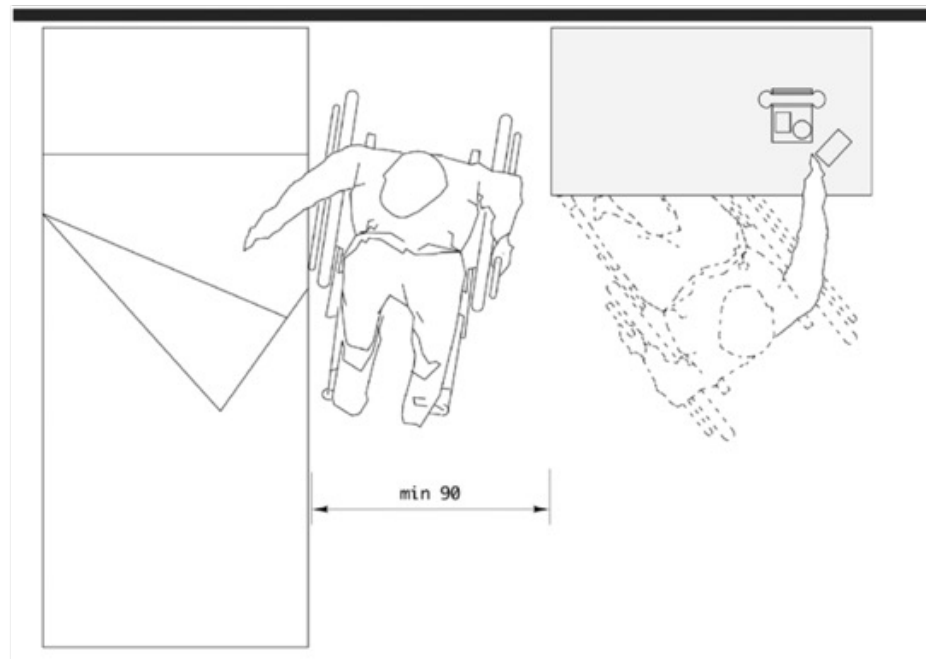
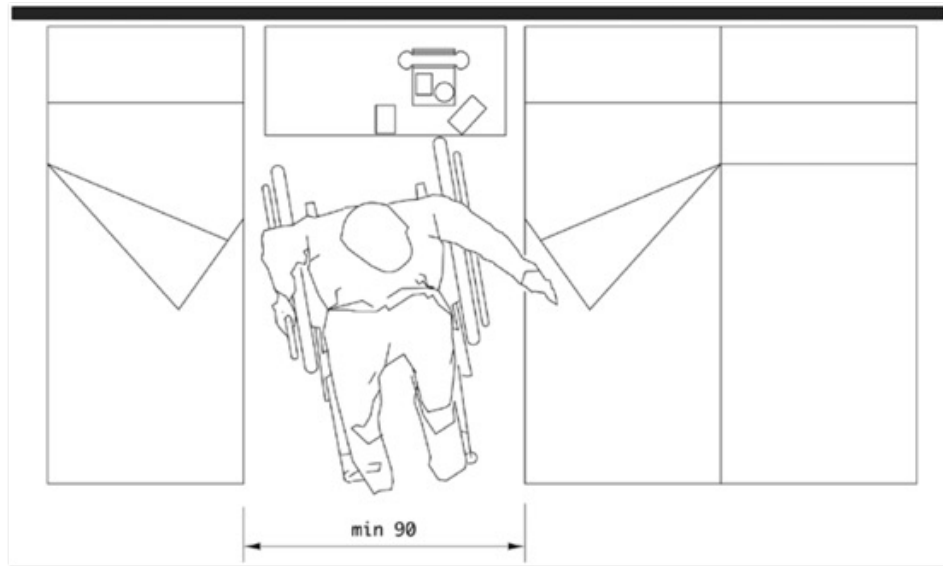



# ACCESSIBILITA' TRASPARENTE

esempio



**WelcomeEverybody**  
Emilia Romagna







**WelcomeEverybody**  
Emilia Romagna





**WelcomeEverybody**  
Emilia Romagna





**WelcomeEverybody**  
Emilia Romagna







WelcomeEverybody  
Emilia Romagna

The collage consists of several overlapping screenshots of web pages:

- Top Left:** A page for 'in Viaggio ASSO' with a login form for 'Utente' and 'Password', and an 'ENTRA' button. Below it is a 'RICERCA VELOCE' section with a search bar and a 'REGISTRATI GRATIS' button.
- Top Center:** A page for 'turismo.parma' with a navigation menu (HOME PAGE, UTENTI, CONTATTI, NEWSLETTER, MAPPA) and a search bar. The main content area is titled 'programmare il viaggio' and includes sections for 'Turismo accessibile' and 'Cerca dove dormire'.
- Top Right:** A page for 'COMUNO DI PARMA' with a navigation menu (HOME, ARCHIVIO FOTO, CORRESPONDENZA) and a search bar. The main content area is titled 'TURISMO OSPITALITÀ' and includes a 'SCOPRI IL TERRITORIO' section and a 'LE MAPPE' section.
- Bottom:** A footer for 'COMUNO DI PARMA' with contact information and logos for 'Informazione e Accoglienza Turistica' and 'Turismo Scolastico'.



# Una premessa

- La «fotografia» dei servizi e degli ambienti **non sostituisce** la relazione diretta (consolidata nel tempo) fra il consumatore (turista) e il produttore di servizi (operatore turistico);
- Non sostituisce ma **sostiene l'importanza** del «passa parola» fra la clientela come valore aggiunto nella comunicazione positiva;

# Il questionario



Welcome Everybody è lo slogan del progetto "In Emilia-Romagna c'è una vacanza per me", approvato e cofinanziato dall'Ufficio per le Politiche in Favore delle Persone con Disabilità della Presidenza del Consiglio dei Ministri, che intende promuovere il turismo accessibile, favorendo la capacità delle località coinvolte di accogliere le esigenze di tutti i turisti.

Il progetto prevede, in estrema sintesi, le seguenti azioni:

- Rilevazione e raccolta di informazioni sulle caratteristiche delle strutture turistiche e dei servizi offerti, tramite la somministrazione di un questionario online.
- Formazione diretta agli imprenditori del turismo e in particolare al personale deputato alla ricezione, per sensibilizzare e preparare all'accoglienza.
- Interventi specifici in alcuni Comuni (installazione/realizzazione di nuovi ausili, strumenti, attrezzature, servizi per l'accessibilità).
- Attivazione di tirocini per giovani con disabilità presso imprese o enti locali.

[Leggi tutto](#)

Scegli il tipo di struttura [?](#)



[Partner ed altri soggetti coinvolti](#)

Powered by **gies**

- I.A.T.
- Struttura ricettiva
- Villaggio turistico
- Museo / Biblioteca
- Ristorazione
- Stabilimento balneare
- ...

# Il questionario

- Anagrafica della struttura e sua collocazione
- Servizi offerti dalla struttura
- Struttura ricettiva
- Parcheggio  
(indicazioni di dettaglio duplicabili)
- Entrata  
(indicazioni di dettaglio duplicabili)
- Reception, Biglietteria, Atrio, Guardaroba  
(indicazioni di dettaglio duplicabili)
- Collegamenti verticali: Ascensore  
(indicazioni di dettaglio duplicabili)
- Collegamenti verticali: Rampa  
(indicazioni di dettaglio duplicabili)
- Collegamenti verticali: Scale  
(indicazioni di dettaglio duplicabili)
- Altre sale presenti nella struttura  
(indicazioni di dettaglio duplicabili)
- Camera/e Rilevata/e  
(indicazioni di dettaglio duplicabili)
- Appartamenti  
(indicazioni di dettaglio duplicabili)
- Bagno / Servizio Igienico  
(indicazioni di dettaglio duplicabili)

Anagrafica della struttura e sua collocazione

Servizi offerti dalla struttura

Struttura ricettiva

...

DATI COMUNI PER TUTTE  
LE STRUTTURE

# Il questionario

- Anagrafica della struttura e sua collocazione
- Servizi offerti dalla struttura
- Struttura ricettiva
- Parcheggio  
(indicazioni di dettaglio duplicabili)
- Entrata  
(indicazioni di dettaglio duplicabili)
- Reception, Biglietteria, Atrio, Guardaroba  
(indicazioni di dettaglio duplicabili)
- Collegamenti verticali: Ascensore  
(indicazioni di dettaglio duplicabili)
- Collegamenti verticali: Rampa  
(indicazioni di dettaglio duplicabili)
- Collegamenti verticali: Scale  
(indicazioni di dettaglio duplicabili)
- Altre sale presenti nella struttura  
(indicazioni di dettaglio duplicabili)
- Camera/e Rilevata/e  
(indicazioni di dettaglio duplicabili)
- Appartamenti  
(indicazioni di dettaglio duplicabili)
- Bagno / Servizio Igienico  
(indicazioni di dettaglio duplicabili)

Parcheggio

Entrata

Atrio, Reception

Collegamenti verticali

AMBIENTE SPECIFICO DELLA  
STRUTTURA PRESA IN ESAME

# Il questionario

- Anagrafica della struttura e sua collocazione
- Servizi offerti dalla struttura
- Struttura ricettiva
- Parcheggio  
(indicazioni di dettaglio duplicabili)
- Entrata  
(indicazioni di dettaglio duplicabili)
- Reception, Biglietteria, Atrio, Guardaroba  
(indicazioni di dettaglio duplicabili)
- Collegamenti verticali: Ascensore  
(indicazioni di dettaglio duplicabili)
- Collegamenti verticali: Rampa  
(indicazioni di dettaglio duplicabili)
- Collegamenti verticali: Scale  
(indicazioni di dettaglio duplicabili)
- Altre sale presenti nella struttura  
(indicazioni di dettaglio duplicabili)
- Camera/e Rilevata/e  
(indicazioni di dettaglio duplicabili)
- Appartamenti  
(indicazioni di dettaglio duplicabili)
- Bagno / Servizio Igienico  
(indicazioni di dettaglio duplicabili)

Sale riunioni

Camere

Appartamenti

Bagni, Servizi igienici

AMBIENTE SPECIFICO DELLA  
STRUTTURA PRESA IN ESAME



**WelcomeEverybody**  
Emilia Romagna

#### Servizi offerti dalla struttura

##### Servizi su richiesta offerti al turista ?

- Servizio di babysitting
- Servizio di sollievo familiare (rivolto a persone anziane) ?
- Servizio di sollievo familiare (rivolto a persone con problemi psichici) ?
- Servizio di animazione rivolto a bambini/e o a persone anziane
- Servizio di accompagnamento per persone non vedenti ?
- Servizio infermieristico
- Servizio per il benessere animale (cani guida per ciechi) ?
- Servizio per il benessere animale (animali da compagnia) ?
- Servizio di concierge ?

##### Servizi per la mobilità della persona ?

- I mezzi messi a disposizione della struttura per la mobilità interna/esterna ?
- Carrozzina manuale ?
- Carrozzina elettronica ?
- Bicicletta
- Ciclomotore
- Elettroscooter ?
- Propulsori a batteria per carrozzine ?
- Triciclo per adulti ?
- Handbike ?
- Triciclo con pedana per carico carrozzina ?
- Servizio navetta
- Servizio di ricarica batteria per carrozzine elettroniche, scooter e monopattini in locale preposto ?
- Noleggio auto
- Colonnine per la ricarica di auto elettriche
- Montascale ?
- Monopattini

# Il questionario

Si indica  solo quello che si ha

##### Servizi su richiesta offerti al turista ?

- Servizio di babysitting
- Servizio di sollievo familiare (rivolto a persone anziane) ?
- Servizio di sollievo familiare (rivolto a persone con problemi psichici) ?
- Servizio di animazione rivolto a bambini/e o a persone anziane
- Servizio di accompagnamento per persone non vedenti ?
- Servizio infermieristico
- Servizio per il benessere animale (cani guida per ciechi) ?

# Il questionario

## Note e immagini di supporto

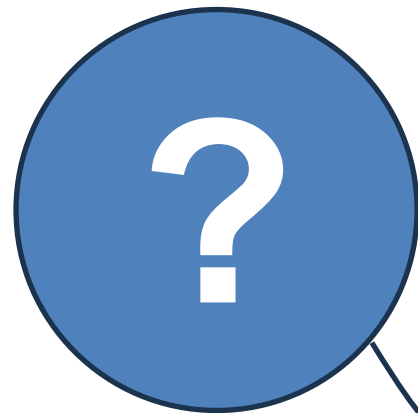

### Informazioni aggiuntive

La destra e la sinistra sono da intendersi durante l'utilizzo del sanitario, ossia da seduto sul WC.

Immagine esplicativa:



SPAZIO LIBERO LATO DESTRO

Ok

### Informazioni aggiuntive

Immagine esplicativa:

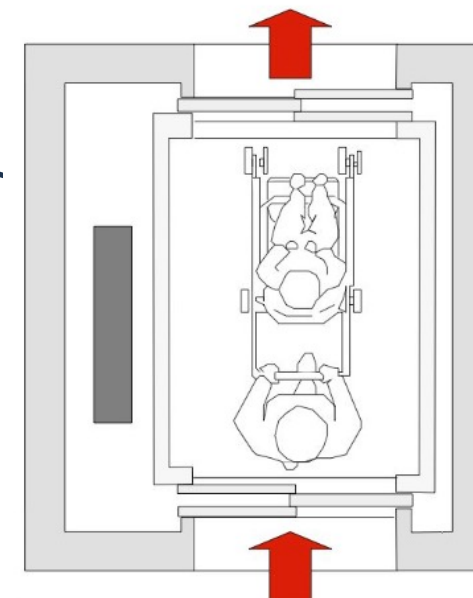

SECONDA PORTA FRONTALE

Ok

### Informazioni aggiuntive

referito alla luce netta di ingresso

Immagine esplicativa:

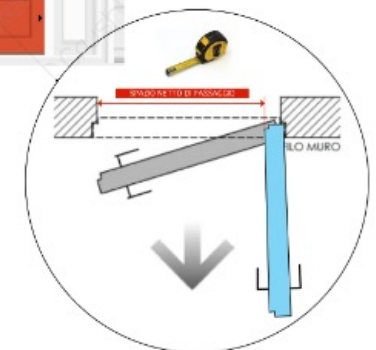

Ok

# Il questionario

## Servizi per la mobilità della persona ?

I mezzi messi a disposizione dalla struttura per la mobilità interna/esterna ?

Carrozzina manuale ?

Carrozzina elettronica ?

Bicicletta

Ciclomotore

Elettroscooter ?

Propulsori a batteria per carrozzine ?

Triciclo per adulti ?

Non sempre i servizi sono previsti all'interno di una struttura

Non è una carenza anzi

La nostra domanda vuole fornire stimoli di riflessione per coloro che con lungimiranza vorranno nel futuro investire in nuove opportunità per attrarre nuove fasce di mercato turistico





WelcomeEverybody  
Emilia Romagna

...e perché no!



Jolly  
Hotel



...e perché no!

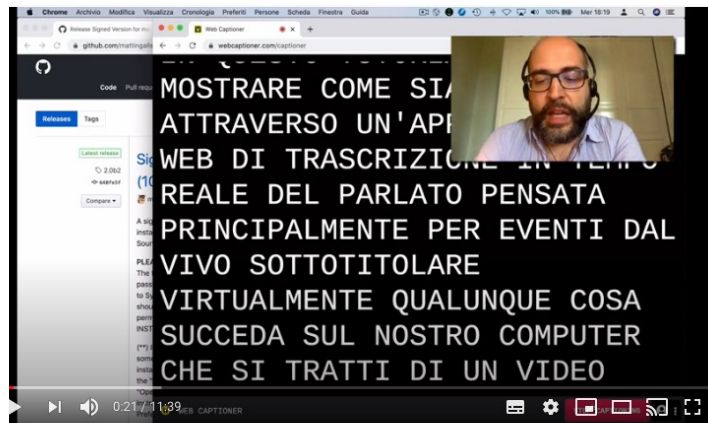
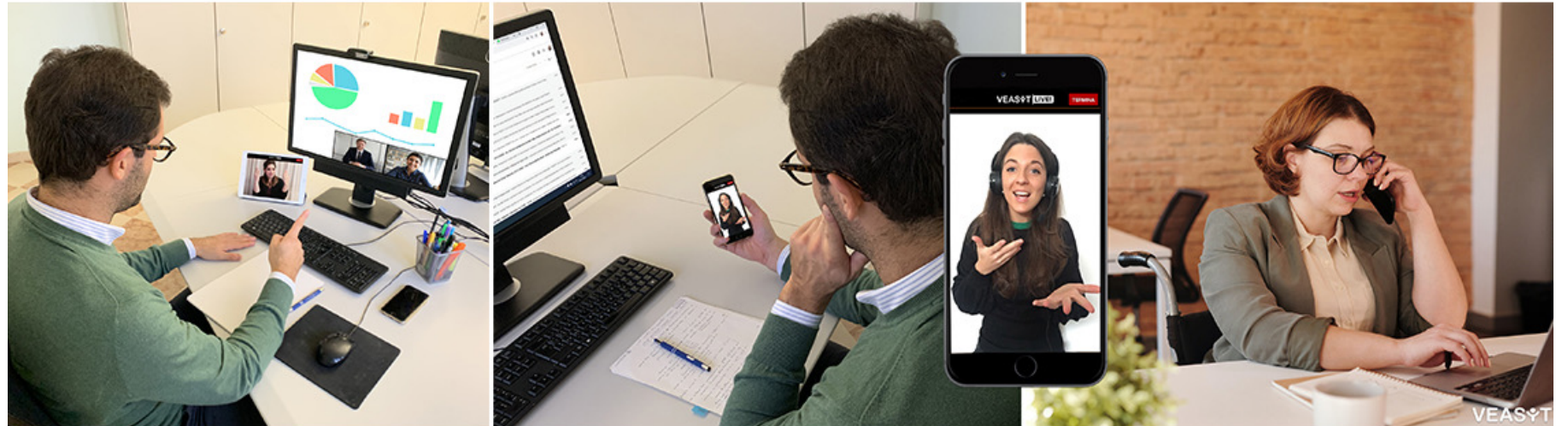



WelcomeEverybody  
Emilia Romagna

...e perché no!

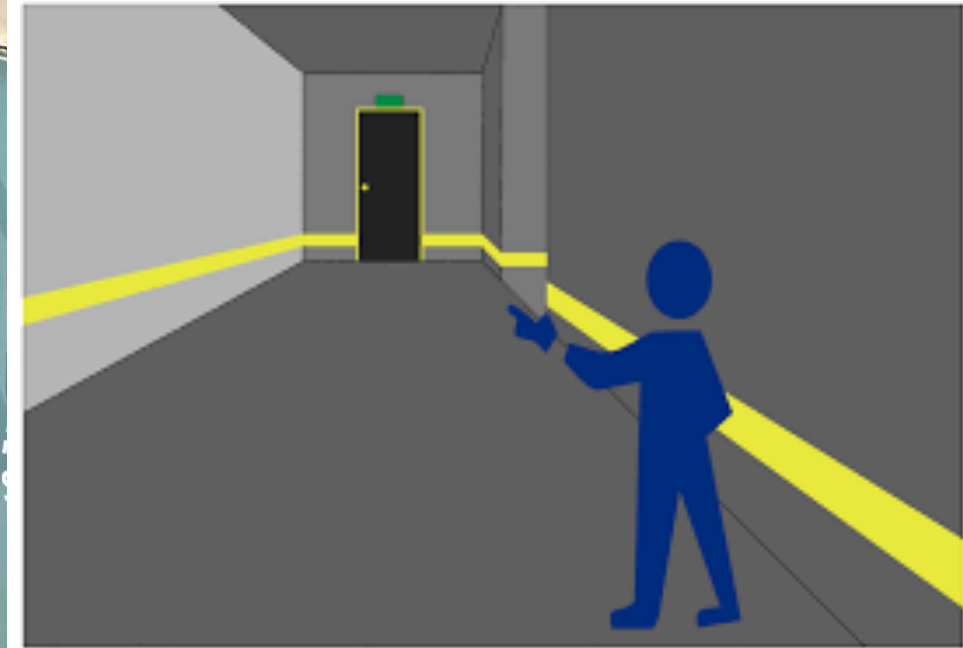

...e perché no!



...e perché no!

# TOVAGLIETTA

**TOVAGLIETTA è pensata per i bambini e tutti coloro che hanno difficoltà comunicative ed è realizzata in Comunicazione Aumentativa Alternativa, un approccio che facilita la comunicazione. Perché la comunicazione è un diritto di tutti!**  
 Giornata Mondiale dell'Autismo - "Ferentino si accende di blu" 1-2 Aprile 2017  
 Asd E...sperimento: [www.facebook.com/asdesperimento](http://www.facebook.com/asdesperimento) - [www.facebook.com/ferentinoblu](http://www.facebook.com/ferentinoblu) - [asdesperimento@gmail.com](mailto:asdesperimento@gmail.com)

### Primi Piatti

CARNE	
Pasticcio di lasagne al forno	€ 7,50
Bis della casa	€ 8,50
Tagliatelle al ragù o al pomodoro	€ 7,50
Tortellini al ragù o al pomodoro	€ 8,00
Gnocchi al ragù o al pomodoro	€ 7,50
Ravioli rosè	€ 7,50
Tagliatelle ai funghi	€ 7,50
Strozzapreti salsiccia e radicchio	€ 7,50
Strozzapreti pasticciati	€ 7,50
Tris Spingarda	€ 9,30
Tortellini panna, prosciutto e funghi	€ 8,90
Gnocchi ai quattro formaggi	€ 8,90
Spaghetti alla carbonara	€ 7,90
Penne all'arrabbiata	€ 6,90
Spaghetti o penne al ragù	€ 6,90
Cappelletti in brodo	€ 8,50
Minestra in brodo di verdura	€ 6,90
Passatelli asciutti ai porcini	€ 9,50
Tagliatelle ai funghi porcini	€ 9,50



DISSE:	IO	VOGLIO	CHE VOI	ABITATE	FELICI	SULLA
MISE	UN ARCOBALENO	NEL CIELO	E DISSE:			
È	IL MIO	SEGNALE	PER TUTTI	GLI UOMINI.		



# Formazione e coaching



ARGOMENTI	APPROFONDIMENTI	MODALITA'
Turismo inclusivo e le opportunità di un mercato in crescita		In presenza Webinar Pillole
Chi è il mio cliente?		Webinar
Strumenti e servizi a supporto	Ambiente e servizi	Webinar
Io ho e quindi sono		Webinar
Accoglienza e comunicazione		Webinar
Focus sui clienti con problemi motori	Le varie sfaccettature	Webinar Pillole
Focus sui clienti con problemi cognitivo-relazionali		Webinar Pillole
Focus sui clienti con problemi sensoriali	Non vedenti, ipovedenti, sordi	Webinar Pillole

# Formazione e coaching



ARGOMENTI	APPROFONDIMENTI	MODALITA'
Focus sui clienti con problemi non visibili		Webinar Pillole
Sicurezza e gestione dell'emergenza		Webinar Pillole
Buone pratiche di ospitalità		Webinar
Come compilare il questionario	IAT	Webinar
	Strutture ricettive	Webinar
	Strutture ristorative	Webinar
	Villaggi e campeggi	Webinar
	Musei / biblioteche	Webinar
	Stabilimenti balneari	Webinar
Criteri di validazione		Webinar

# Supporto tecnico (compilazione del questionario)

## HELP-DESK

DICEMBRE 2023  
LUGLIO 2024



dal lunedì al venerdì  
ore 10:00 - 12:00



340 213 1095

- Una persona guiderà l'operatore all'interpretazione delle richieste previste all'interno del questionario o fornire suggerimenti per l'organizzazione dei dati.
- E' possibile contattare o anticipare la richiesta verso l'helpdesk attraverso il servizio WhatsApp.



# Supporto tecnico

(supporto tecnico per il miglioramento delle performance della struttura tramite audit a richiesta)

HELP-DESK

DICEMBRE 2023  
LUGLIO 2024



[consulenze@criba-er.it](mailto:consulenze@criba-er.it)

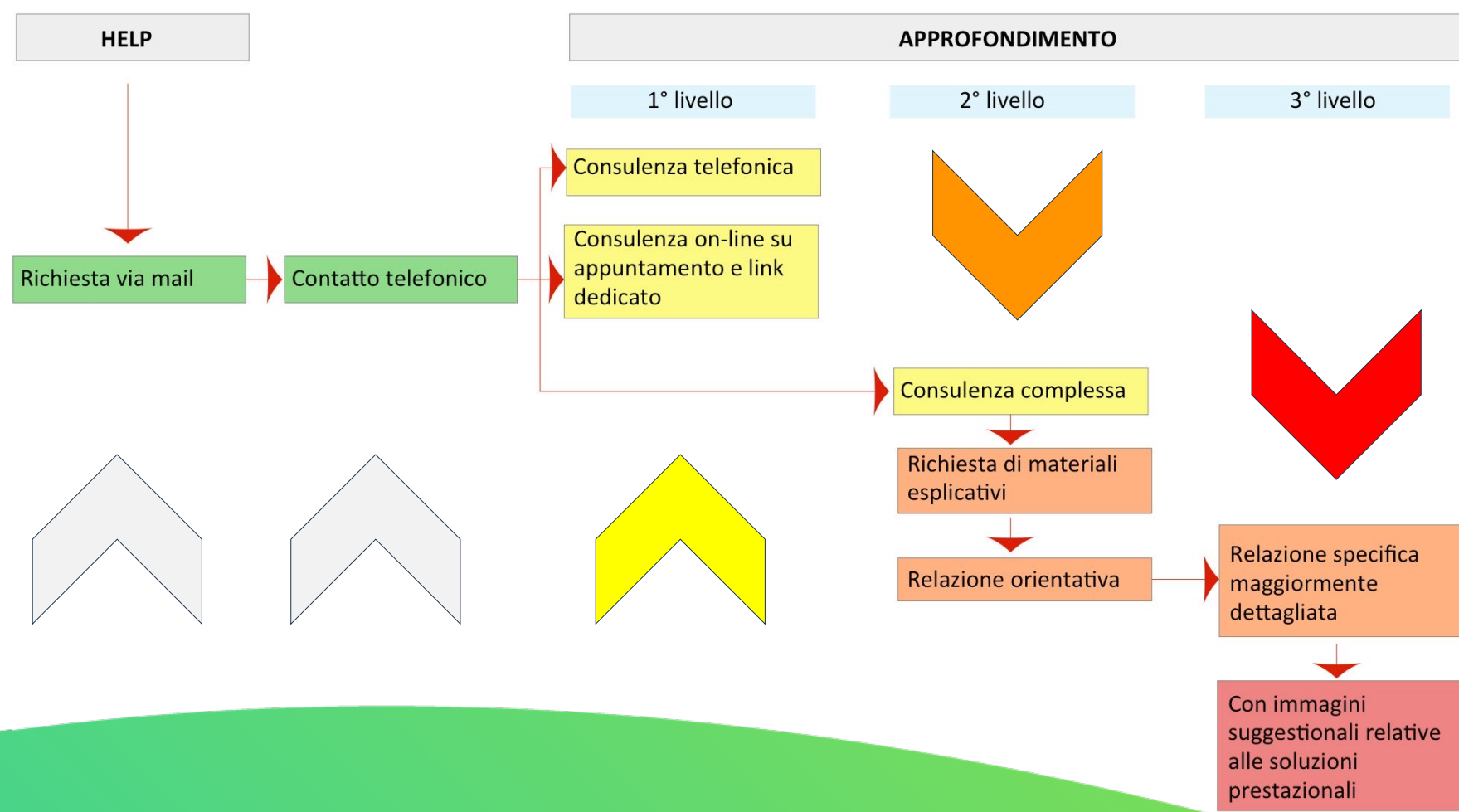

# La validazione

Ai fini della migliore messa a punto del sistema informativo, le verifiche a **campione** potranno estendersi oltre la conclusione del progetto (8/9/2024) anche se esaurita la fase di sperimentazione.

**Al completamento della fase di perfezionamento delle funzionalità del sistema, la fase di verifica e controllo si esaurirà.**



# ...l'importanza di dati precisi



# *Grazie!*



**WelcomeEverybody**  
Emilia Romagna